

PV ARRAY INFORMATION (Guide Sec. 6)

NUMBER OF MODULES IN SERIES _____

NUMBER OF PARALLEL CIRCUITS _____

LOWEST EXPECTED AMBIENT TEMP _____ °C

HIGHEST CONTINUOUS TEMPERATURE _____ °C

**OCPD = OVERCURRENT PROTECTION DEVICE
(IF NO OCPD-PUT "N/A" IN RELEVANT BLANKS)**

**NATIONAL ELECTRICAL CODE® REFERENCES
SHOWN AS (NEC XXX.XX)**

_____ MODULES IN SERIES SOURCE-CIRCUIT

_____ MODULES IN SERIES SOURCE-CIRCUIT

_____ MODULES IN SERIES SOURCE-CIRCUIT

_____ MODULES IN SERIES SOURCE-CIRCUIT

SOURCE-CIRCUIT COMBINER RATINGS (IF USED)

MAX OCPD RATING = _____ A

OCPD AMP RATING = _____ A

OCPD VOLT RATING = _____ V

DC DISCONNECT RATINGS (See Guide Appendix B)

DISCO AMP RATING = _____ A

DISCO VOLT RATING = _____ V

INVERTER RATINGS (Guide Sec. 4)

INVERTER MAKE _____

INVERTER MODEL # _____

MAX DC VOLT RATING = _____ V

MAX POWER @ 40°C = _____ W

NOMINAL AC VOLTAGE = _____ V

MAX AC CURRENT = _____ A

MAX OCPD RATING = _____ A

**AC DISCONNECT RATINGS (IF USED)
(See Guide Appendix B)**

DISCO AMP RATING = _____ A

DISCO VOLT RATING = _____ V

UTILITY SERVICE

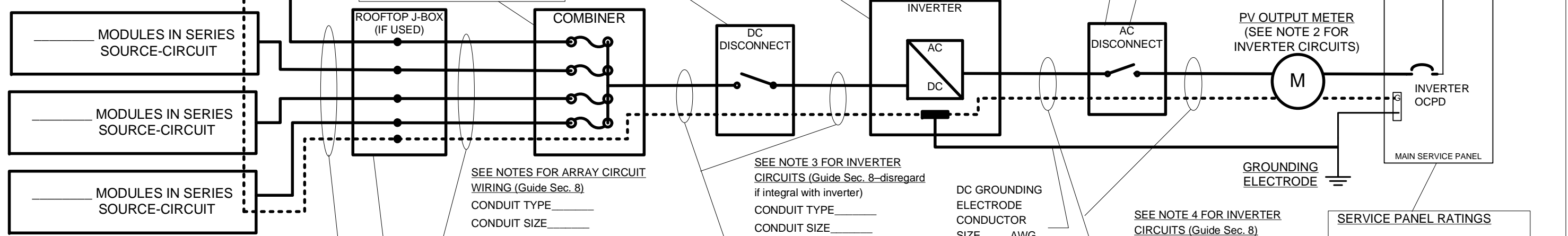

**FOR UNUSED SERIES STRINGS
PUT "N/A" in BLANK ABOVE**

**SEE GUIDE SECTION 10 FOR
INFORMATION ON MODULE
AND ARRAY GROUNDING**

**SEE NOTES FOR ARRAY CIRCUIT
WIRING (Guide Sec. 8)**

CONDUIT TYPE _____

CONDUIT SIZE _____

CONDUCTOR TYPE (SEE BELOW)

CONDUCTOR SIZE _____ AWG

NUMBER OF CONDUCTORS _____

(____ Red, ____ White, 1 Green)

EGC SIZE _____ AWG (NEC 250.122)

**SEE NOTE 3 FOR INVERTER
CIRCUITS (Guide Sec. 8—disregard
if integral with inverter)**

CONDUIT TYPE _____

CONDUIT SIZE _____

CONDUCTOR TYPE _____

CONDUCTOR SIZE _____ AWG

NUMBER OF CONDUCTORS _____

(____ Red, ____ White, 1 Green)

EGC SIZE _____ AWG (NEC 250.122)

**DC GROUNDING
ELECTRODE
CONDUCTOR
SIZE _____ AWG
(NEC 250.166,
Guide Sec. 10)**

**SEE NOTE 4 FOR INVERTER
CIRCUITS (Guide Sec. 8)**

CONDUIT TYPE _____

CONDUIT SIZE _____

CONDUCTOR TYPE _____

CONDUCTOR SIZE _____ AWG

NUMBER OF CONDUCTORS _____

(____ Black, ____ Red, ____ White,
____ Green)

EGC SIZE _____ AWG (NEC 250.122)

SERVICE PANEL RATINGS

BUS AMP RATING = _____ A

SERVICE VOLTAGE = _____ V

MAIN OCPD RATING = _____ A

INVERTER OCPD
AMPERE RATING = _____ A

(SEE NOTE 5 FOR INVERTER OCPDs
BELOW, ALSO SEE GUIDE SECTION 9)

PV MODULE RATINGS @ STC (Guide Sec. 5)

MODULE MANUFACTURER _____

MODULE MODEL # _____

MAX POWER-POINT CURRENT (I_{mp}) = _____ A

MAX POWER-POINT VOLTAGE (V_{mp}) = _____ V

OPEN-CIRCUIT VOLTAGE (V_{oc}) = _____ V

SHORT-CIRCUIT CURRENT (I_{sc}) = _____ A

MAX SERIES FUSE (OCPD) = _____ A

MAXIMUM POWER (P_{max}) = _____ W

MAX SYSTEM VOLTAGE (typ 600Vdc) = _____ V

V_{oc} TEMP COEFF = _____ mV/°C or %/°C
(IF SUPPLIED, CIRCLE TYPE OF COEFF)

**ROOFTOP JUNCTION BOX
NEMA 3R MINIMUM REQUIRED
WITH WATERPROOF SPLICES
OR OTHER APPROVED
TERMINATION METHOD
(NEC 110.14; 300.6; 314)**

**SOURCE-CIRCUIT CONDUCTORS
OUTSIDE CONDUIT—MINIMUM 12 AWG
AND TWO TYPE OPTIONS—(CIRCLE ONE)
USE-2; PV WIRE/CABLE**

SIGNS—SEE GUIDE SECTION 7

<p>SIGN FOR DC DISCONNECT</p> <p>PHOTOVOLTAIC POWER SOURCE</p> <p>RATED MPP CURRENT = _____ A</p> <p>RATED MPP VOLTAGE = _____ V</p> <p>MAX SYSTEM VOLTAGE = _____ V</p> <p>MAX CIRCUIT CURRENT = _____ A</p> <p>WARNING: ELECTRICAL SHOCK HAZARD—LINE AND LOAD MAY BE ENERGIZED IN OPEN POSITION</p>	<p>SIGN FOR AC DISCONNECT (if used)</p> <p>SOLAR AC DISCONNECT</p> <p>AC OUTPUT CURRENT = _____ A</p> <p>NOMINAL AC VOLTAGE = _____ V</p> <p>SIGN FOR INVERTER OCPD</p> <p>AC POINT OF CONNECTION</p> <p>AC OUTPUT CURRENT = _____ A</p> <p>NOMINAL AC VOLTAGE = _____ V</p>
--	--

NOTES FOR INVERTER CIRCUITS (Guide Sec. 8):

- 1) IF UTILITY REQUIRES A VISIBLE-BREAK SWITCH, DOES THIS SWITCH MEET THE REQUIREMENT? YES/NO (CIRCLE ONE)
- 2) IF GENERATION METER REQUIRED, DOES THIS METER SOCKET MEET THE REQUIREMENT? YES/NO (CIRCLE ONE)
- 3) SIZE PHOTOVOLTAIC POWER SOURCE (DC) CONDUCTORS BASED ON MAX CURRENT ON 690.53 SIGN OR OCPD RATING AT DISCONNECT (IF SUPPLIED)
- 4) SIZE INVERTER OUTPUT CIRCUIT (AC) CONDUCTORS ACCORDING TO INVERTER OCPD AMPERE RATING.
- 5) TOTAL OF _____ INVERTER OCPD(S), ONE FOR EACH INVERTER. DOES TOTAL SUPPLY BREAKERS COMPLY WITH 120% BUSBAR EXCEPTION IN 690.64(B)(2)(a)? YES/NO (CIRCLE ONE)

NOTES FOR ARRAY CIRCUIT WIRING (Guide Sec. 8):

- 1.) THREE OPTIONS FOR SOURCE CIRCUIT CONDUCTOR TYPE (INSIDE CONDUIT—CIRCLE ONE) THWN-2; XHHW-2; RHW-2
- 2.) 2005 ASHRAE FUNDAMENTALS 2% DESIGN TEMPERATURES DO NOT EXCEED 47°C IN THE UNITED STATES (PALM SPRINGS, CA IS 44.1°C). FOR LESS THAN 9 CURRENT-CARRYING CONDUCTORS IN ROOF-MOUNTED SUNLIT CONDUIT AT LEAST 0.5" ABOVE ROOF AND USING THE OUTDOOR DESIGN TEMPERATURE OF 47°C OR LESS (ALL OF UNITED STATES).
 - a) 12 AWG, 90°C CONDUCTORS ARE GENERALLY ACCEPTABLE FOR MODULES WITH I_{sc} OF 7.68 AMPS OR LESS WHEN PROTECTED BY A 12-AMP OR SMALLER FUSE.
 - b) 10 AWG, 90°C CONDUCTORS ARE GENERALLY ACCEPTABLE FOR MODULES WITH I_{sc} OF 9.6 AMPS OR LESS WHEN PROTECTED BY A 15-AMP OR SMALLER FUSE.

Contractor Name and Address:		Standard Electrical Diagram for Small-Scale, Single-Phase PV Systems			
Site Name: _____ Site Address: _____ System AC Size: _____					
Drawn By:	SIZE	FSCM NO	DWG NO	REV	
Checked By:	SCALE	NTS	Date:	SHEET	
			E1.1	0	