

Inspecting PV Systems for Code-Compliance

Course Manual

Compiled by

Brooks Engineering, LLC

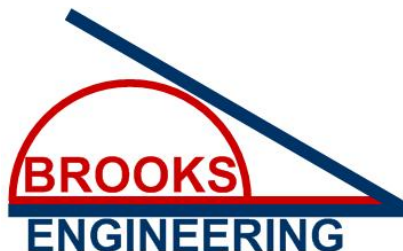

This page intentionally left blank

INSPECTING PHOTOVOLTAIC (PV) SYSTEMS FOR CODE-COMPLIANCE

Presented by
Bill Brooks, PE
Brooks Engineering

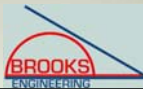

Expedited Permit Process for PV Systems

available at
www.irecusa.org or
www.brookSolar.com

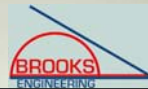

Why do we need Permit Guidelines?

- Variations in compliance requirements—some are insufficient to protect the public, others may not be consistent with established standards.
- Need a predictable process with uniform enforcement of code requirements for jurisdictional authorities and installing contractors.



Overview of Presentation

- PV System Basics
- Introduction to relevant Codes and Standards
- Permit and Field Inspector Guidelines for PV Systems
- Summary of Changes in 2005/2008 National Electrical Code



What are the objectives of the guidelines?

- Facilitate the installation of safe systems at a minimum of cost.
- Provide guidance on what information should be provided for permitting.
- Discourage “fly-by-nights” from the industry by making them do all the steps that a good installer does.
- Raise the professionalism of installing contractors.



What is the basic approach used to develop the guidelines?

- Originally based on the 2002 NEC, Article 690, and various guidelines from a few jurisdictions and using input from several experienced professionals including installers and inspectors throughout the U.S. It has since been updated for the 2005 National Electrical Code.
- In addition to national experts, California has over 45,000 systems that have been inspected by local jurisdictions. This is an experience base not previously available.
- Approach is to establish a set of best practices that will help ensure that the public safety is preserved when an installation meets these guidelines



Who will benefit from these guidelines?

- Jurisdictions in charge of public safety in the built environment (authority having jurisdiction or AHJ).
- Plan checkers and field inspectors tasked with reviewing PV systems.
- Installers who need consistent criteria in which to have their systems reviewed.



PV Codes and Standards 101



What are the applicable codes and standards for PV systems?

- Electrical codes - NEC Article 690 - Solar Photovoltaic Systems – NFPA 70
- Uniform Solar Energy Code – ICC
- Building Codes – ICC, ASCE 7-05
- UL Standard 1703, Flat-plate Photovoltaic Modules and Panels
- IEEE 1547, Standard for Interconnecting Distributed Resources with Electric Power Systems
- UL Standard 1741, Standard for Inverters, Converters, Controllers and Interconnection System Equipment for Use With Distributed Energy Resources



Photovoltaic System *Basics*

stuff you have to know to understand the NEC



Definitions: PV Cell

- **Cell:** The basic photovoltaic device that is the building block for PV *modules*.

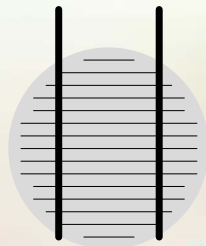

Connect Cells To Make Modules

- One silicon solar cell produces 0.5 volt
- 36 cells connected together have enough voltage to charge 12 volt batteries and run pumps and motors
- 72-cell modules are the new standard for grid-connected systems having a nominal voltage of 24-Volts and operating at about 30 Volts.
- Module is the basic building block of systems
- Can connect modules together to get any power configuration



PV Performance Parameters

- Open-circuit voltage (V_{oc})
- Short-circuit current (I_{sc})
- Maximum power voltage (V_{mp})
- Maximum power current (I_{mp})
- Maximum power (P_{mp})

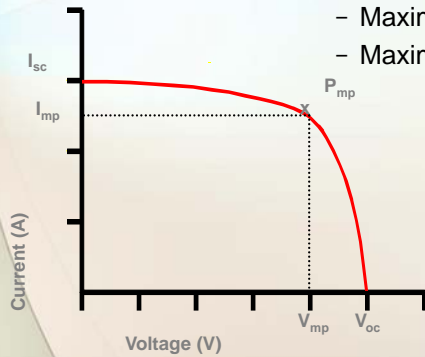

Current varies with irradiance

Siemens Solar Module SP75
Performance at Different Irradiances

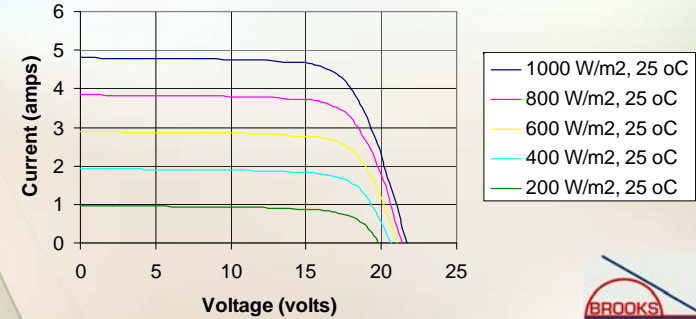

Voltage varies with temperature

Siemens Solar Module SP75
Performance at Different Cell Temperatures

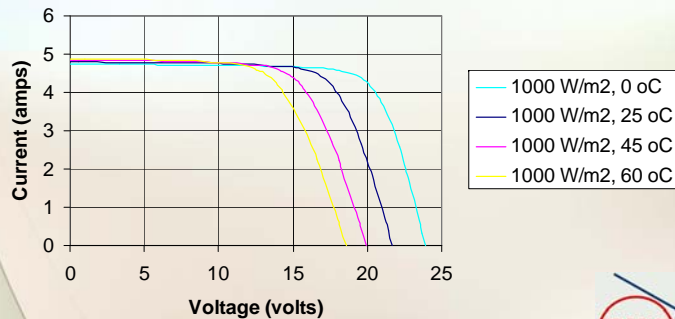

Definitions: PV Module

- Module: A group of PV cells connected in series and/or parallel and encapsulated in an environmentally protective laminate.

Polycrystalline Silicon module



Monocrystalline Silicon module

Integrated PV Modules



Definitions: PV Panel

- **Panel:** A structural group of *modules* that is the basic building block of a PV *array*.



Definitions: PV Array

- **Array:** A group of *panels* that comprises the complete direct current PV generating unit.



Definitions: Balance of System (BOS)

- **BOS:** The balance of the equipment necessary to integrate the PV array with the site load (building). This includes the array circuit wiring, fusing, disconnects, and power processing equipment (inverter).



Block diagram of PV system without battery backup

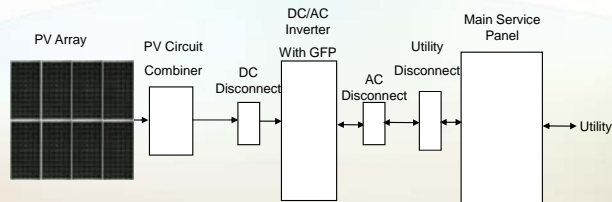

Block diagram of PV system with battery backup

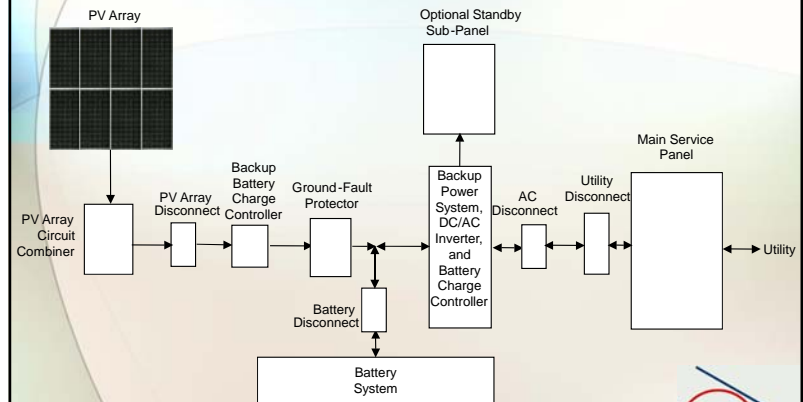

Differences Between PV and Conventional Electrical Systems

- PV systems have *dc circuits* that require special design and equipment.
- PV systems can have *multiple energy sources*, and special disconnects are required to isolate components.
- Energy flows in PV systems may be *bi-directional*.
- Utility-Interactive PV systems require an interface with the ac utility-grid and special considerations must be adopted. (utility must be involved-hence utility training)



PV System Electrical Design: Common Problem Areas

- *Insufficient* conductor ampacity and insulation
- *Excessive voltage drop*
- *Unsafe* wiring methods
- *Lack of or improper* placement of overcurrent protection and disconnect devices
- *Use of unlisted*, or improper application of listed equipment (e.g. ac in dc use)
- *Lack of or improper* equipment or system grounding
- *Unsafe* installation and use of batteries



Ain't that purdy....



...and this is so much prettier...



Expedited Permit Process for Small-Scale PV Systems



Purpose

- The information in this guideline is intended to help local jurisdictions and contractors identify when PV system installations are simple, needing only a basic review, and when an installation is more complex. It is likely that 50%-75% of all residential systems will comply with these simple criteria. For projects that fail to meet the simple criteria, a resolution step is suggested to provide a path to permit approval.



Required Information for Permit

- Site plan showing location of major components on the property. This drawing need not be exactly to scale, but it should represent relative location of components at site (see supplied example site plan). PV arrays on dwellings with a 3' perimeter space at ridge and sides do not need fire service approval.
- Electrical diagram showing PV array configuration, wiring system, overcurrent protection, inverter, disconnects, required signs, and ac connection to building (see supplied standard electrical diagram).
- Specification sheets and installation manuals (if available) for all manufactured components including, but not limited to, PV modules, inverter(s), combiner box, disconnects, and mounting system.



Site Diagram

- Drawing does not need to be to scale, but it should basically show where the major components are located.
- If array is ground mounted, it should show that it conforms with allowable setbacks.

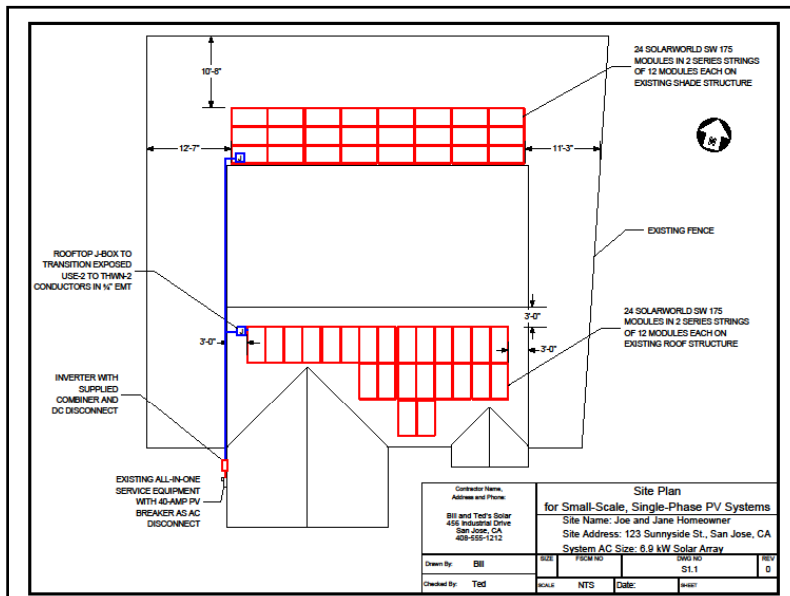

One-line Diagram

- Should have sufficient detail to call out the electrical components, the wire types and sizes, number of conductors, and conduit type and size where needed.
- Should include information about PV modules and inverter(s).
- Should include information about utility disconnecting PV means (required by many utilities).



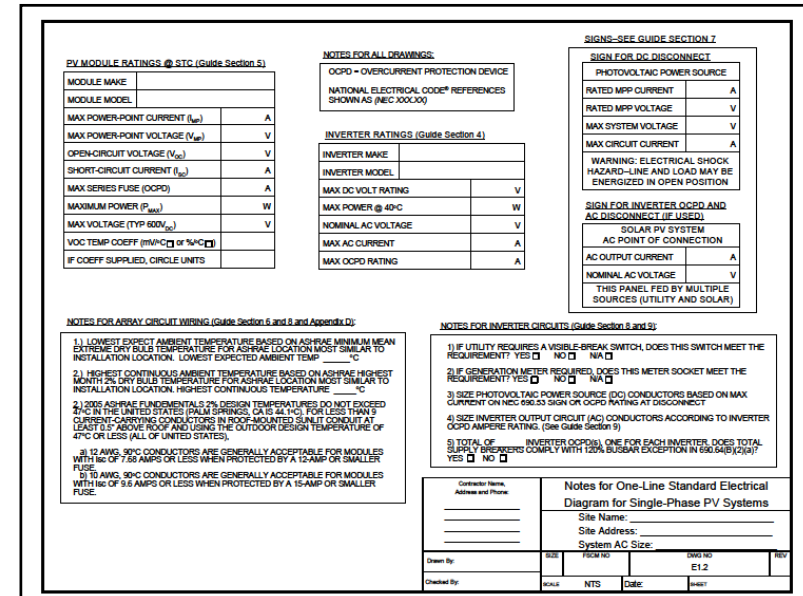
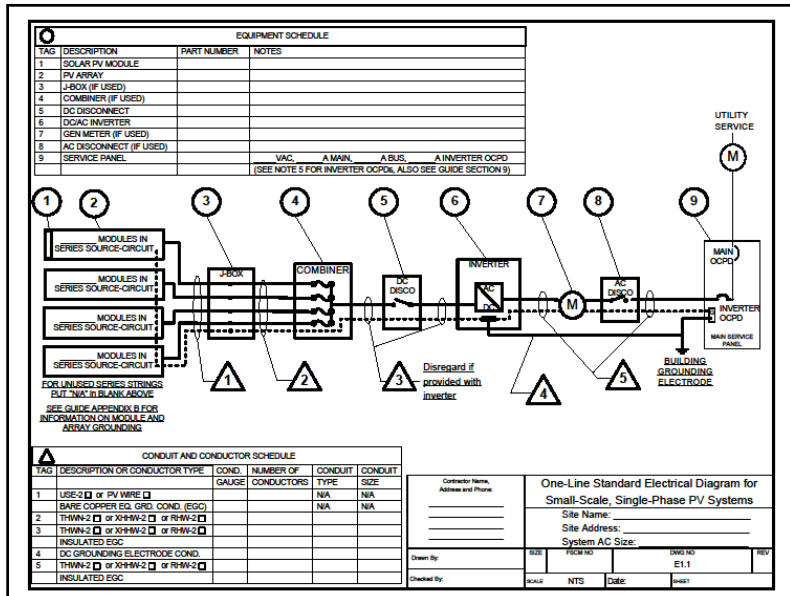

Major Component and Array Electrical Information

- Inverter information
- Module information
- Combiner Box
- Disconnects

Step 1: Structural Review of PV Array Mounting System

- Is the array to be mounted on a defined, permitted roof structure? Yes/No (structure meets modern codes)
- *If No due to non-compliant roof or ground mount, submit completed worksheet for roof structure WKS1.*

Roof Information:

- Is the roofing type lightweight (Yes = composition, lightweight masonry, metal, etc...)_____
- If No, submit completed worksheet for roof structure WKS1 (No = heavy masonry, slate, etc...).
- Does the roof have a single roof covering? Yes/No
- If No, submit completed worksheet for roof structure WKS1.
- Provide method and type of weatherproofing roof penetrations (e.g. flashing, caulk)._____



Mounting System Information:

- The mounting structure is an engineered product designed to mount PV modules?
Yes/No
- If No, provide details of structural attachment certified by a design professional.
- For manufactured mounting systems, fill out information on the mounting system below:



Mounting System Information:

- Mounting System Manufacturer _____ Product Name and Model# _____
- Total Weight of PV Modules and Rails _____ lbs
- Total Number of Attachment Points _____
- Weight per Attachment Point ($b \div c$) _____ lbs (if greater than 40 lbs, see WKS1)
- Maximum Spacing Between Attachment Points on a Rail _____ inches (see product manual for maximum spacing allowed based on maximum design wind speed)
- Total Surface Area of PV Modules (square feet) _____ ft^2
- Distributed Weight of PV Module on Roof ($b \div f$) _____ lbs/ft^2
- If distributed weight of the PV system is greater than 5 lbs/ft^2 , see WKS1.



Step 2: Electrical Review of PV System (Calculations for Electrical Diagram)

- In order for a PV system to be considered for an expedited permit process, the following must apply:
 1. PV modules, utility-interactive inverters, and combiner boxes are identified for use in PV systems.
 2. The PV array is composed of 4 series strings or less, and 15 kW_{STC} or less.
 3. The inverter has a continuous power output 13,440 Watts or less
 4. The ac interconnection point is on the load side of service disconnecting means (690.64(B)).
 5. The electrical diagram (E1.1) can be used to accurately represent the PV system.



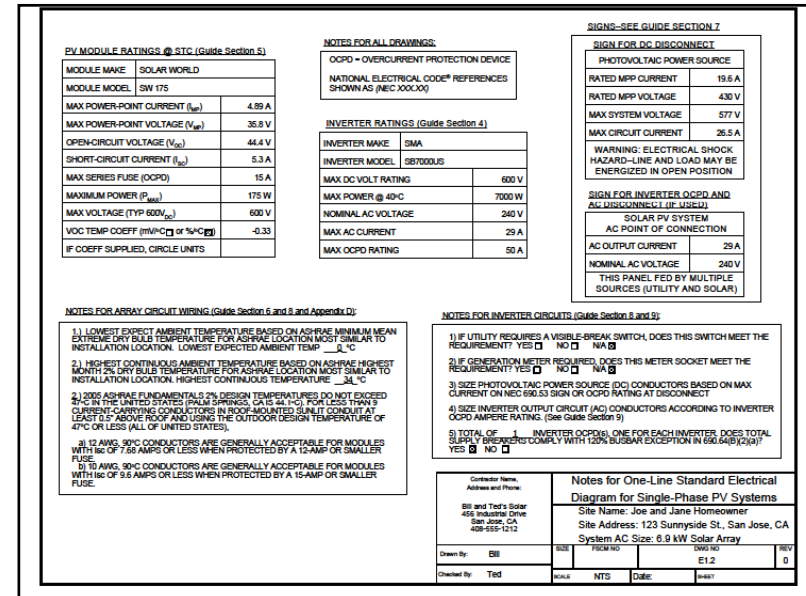
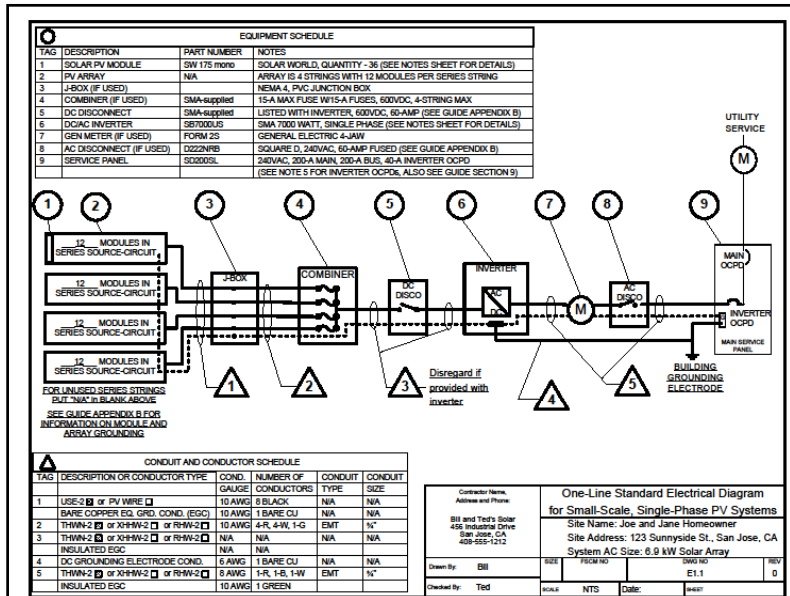

Inverter information

- Model number and manufacturer's "cut sheets" for the specific model.
- Listing—is the inverter listed to UL1741 and labeled "Utility-Interactive"? For a current list of compliant inverters, visit the California Solar Program website. www.gosolarcalifornia.com
- Maximum continuous output power at 40°C
- Input voltage range

Module information

- Manufacturer's "cut sheets" for the specific model.
- Listing. The module should be listed to UL 1703. For a current list of modules that are listed to UL 1703, visit the California website. www.gosolarcalifornia.com
- Listing label information

Typical PV Module Label

PHOTOVOLTAIC MODULE			
MODEL	KC120-1		
SER. NO.	01632A1055		
DATE	2001.6		
IRRADIANCE AND CELL TEMPERATURE	1000W/m ² AM 1.5 25 °C	800W/m ² AM 1.5 47 °C	MAX. SYS. VOLT.
			600 V
P _{max}	120 W	87 W	SERIES FUSE
V _{pmax}	16.9 V	15.2 V	
I _{pmax}	7.10 A	5.74 A	MASS
V _{oc}	21.5 V	---	
I _{sc}	7.45 A	---	11.9 kg
UL LISTED BP82	FIELD WIRING STRANDED COPPER ONLY 10 - 14 AWG INSULATED FOR 90°C		FIRE RATING CLASS C

Array electrical information

- Number of modules in series
- Array operating voltage
- Array operating current
- Maximum system voltage
- Array short circuit current

NEC Article 690 overview

PV Systems and the NEC

- **Article 690** addresses safety standards for the installation of PV systems.
- Many other articles of the NEC may also apply to most PV installations.

NEC Sections Applicable to PV Systems

- Article 110: Requirements for Electrical Installations
- Chapter 2: Wiring and Protection
 - Most of the chapter—especially
 - Article 250: Grounding
- Chapter 3: Wiring Methods and Materials
 - Most of the chapter—especially
 - Article 300: Wiring Methods
 - Article 310: Conductors for General Wiring
- Article 480: Storage Batteries
- Article 690: Solar Photovoltaic Systems



NEC Article 690: Solar Photovoltaic Systems

- I. General (definitions, installation)
- II. Circuit Requirements (sizing, protection)
- III. Disconnect Means (switches, breakers)
- IV. Wiring methods (connectors)
- V. Grounding (array, equipment)
- VI. Markings (ratings, polarity, identification)
- VII. Connection to Other Sources
- VIII. Storage batteries
- IX. Systems over 600 Volts



NEC Article 690: Solar Photovoltaic Systems

- I. General (definitions, installation)
 - 690.1 Scope—PV Systems (only)
 - 690.2 Definitions—PV Output Circuit, Inverter Input Circuit—1 ½ pages of PV-specific jargon
 - 690.3—"Wherever the requirements of other articles of this Code and Article 690 differ, the requirements of Article 690 shall apply"
 - 690.4—Installation "Equipment: ...shall be identified and listed for the application"
 - 690.5—Ground-Fault Protection—to reduce fire hazards
 - 690.6—AC Module—dc wiring is considered internal



Electrical Equipment Listing

- AHJs generally require listing for components and electrical hardware.
- Some components available for PV systems may not have applicable or any listing.
- Recognized testing laboratories include:
 - UL
 - ETL Semko (Intertek)
 - CSA
 - TÜV



NEC Article 690: Solar Photovoltaic Systems

- II. Circuit Requirements (sizing, protection)
 - 690.7 Maximum Voltage—Table 690.7 and manufacturers data. Max. 600Vdc for residential.
 - 690.8 Circuit Sizing and Current
 - 690.8(A) Max current = rated I_{sc} x 1.25 = I_{max}
 - 690.8(B) Min ampacity and overcurrent = I_{max} x 1.25
 - 690.9 Overcurrent Protection
 - 690.9(A) Generally required on all source circuits—exception: a.)no backfeed; and, b.) total I_{max} less than conductor ampacity.
 - 690.10 Stand-Alone Systems
 - Inverter output need only meet demand.
 - No multi-wire circuits on 120V inverters.



NEC Article 690: Solar Photovoltaic Systems

- III. Disconnect Means (switches, breakers)
 - 690.13—Need to disconnect all conductors connected to building. No disconnect in grounded conductor
 - 690.14—Location—details and options (more to come)
 - 690.17—Switch or Circuit Breaker—Warning sign when line and load energized in open position.



NEC Article 690: Solar Photovoltaic Systems

- IV. Wiring methods
 - 690.31(A) FPN—PV modules get HOT
 - 690.31—single conductors outside conduit allowed in array.
 - Table 690.31—temp. correction must be applied to conductors.
 - 690.33—requirements for connectors.
 - 690.35—Ungrounded PV Power Systems



NEC Article 690: Solar Photovoltaic Systems

- V. Grounding (system, equipment)
 - 690.41 System Grounding
 - Over 50Vdc must be grounded or comply with 690.35
 - 690.42 Point of System Grounding Connection—one point, at GFP device if provided.
 - 690.43 Equipment Grounding—metal likely to become energized must be grounded—listed equipment can be used to bond modules to support structure..
 - 690.45 Size of EGC—Table 250.122 with GFP
 - 690.47 Size of GEC—ac use Table 250.66; dc use Table 250.166



Electrical System Grounding

- The NEC defines grounding as a connection to the *earth* with sufficiently low impedance and having sufficient current-carrying capacity to prevent the buildup of voltages.
- Grounding of electrical systems offers personnel safety and minimizes the effects of lightning and surges on equipment.



Electrical Grounding Types (Huge Confusion Over These Terms)

- System Ground (grounding): Connecting the circuit to ground (i.e. the negative of a dc array, the neutral of a split single-phase system, or the neutral of a bi-polar dc system)
- Equipment Ground (bonding): Connecting all non-current carrying metal parts to ground (metal enclosure, module frame, etc...)



Equipment Grounding -Special Focus—Array Grounding

- Due to confusion and ignorance, array grounding methods have been inconsistent, poorly communicated, and often ignored by module manufacturers, structure manufacturers, engineers, contractors, and inspectors (have I left anyone out that I could offend here?).



Stainless Star washer bonding module to rack



How about those Cad-plated fasteners and Tek screws to rails



Great for Hanging Cables



Copper touching Aluminum -not good



Nice Lugs! (poor fasteners)



Thank God for High Resolution—Who Said use Manufacturer’s Directions to Ground Modules?

690.43 Equipment Grounding [2008 NEC]

- “Devices listed and identified for grounding the metallic frames of PV modules shall be permitted to bond the exposed metallic frames of PV modules to grounded mounting structures. Devices identified and listed for bonding the metallic frames of PV modules shall be permitted to bond the exposed metallic frames of PV modules to the metallic frames of adjacent PV modules.”

Early Improvements for Grounding

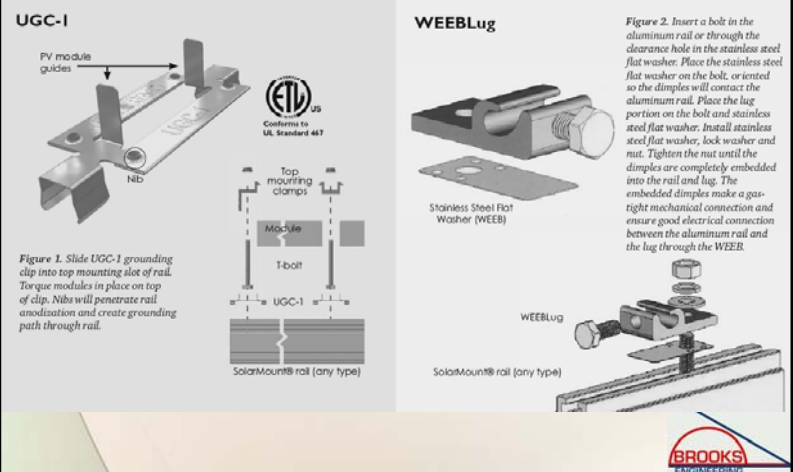



Instead of connecting a ground wire to each and every module, the array is grounded directly to the rails with the patented Sharp talon clip, greatly reducing labor time and complexity.

Integrated grounding.
Now available with the **ONENERGY** solar system

This is huge. The OnEnergy solar system has a unique racking design that eliminates module-to-module grounding. The rail is actually the grounding element — reducing wire, lugs and saving all kinds of installation time. You're finished and ready for your next big opportunity.

NEC Article 690: Solar Photovoltaic Systems

- VI. Markings (ratings, polarity, identification)
 - 690.53—DC PV Power Source—4 items; rated current, rated voltage, max voltage, max current
 - 690.54—Interactive System Point of Interconnection—rated ac current and voltage
 - 690.56—Sign at service entrance when PV disconnect not located at the service disconnect.

NEC Article 690: Solar Photovoltaic Systems

- VII. Connection to Other Sources
 - 690.60 Listed inverters for grid-connected systems
 - 690.61 inverter deenergize when utility is out (part of listing process)
 - 690.64 Point of Connection
 - 690.64(A) Supply Side—230.82
 - 690.64(B) Load Side—dedicated breaker; 120% of busbar or conductor; 2008 NEC requires sign and breaker location to obtain 120% allowance for all PV systems.
- VIII. Storage Batteries
- IX. Systems over 600 Volts



TVA Interconnection Requirements



Requirements based on Size

- Tier 1 - 10 kW or less;
- Tier 2 - Greater than 10 kW and less than or equal to 100 kW; or
- Tier 3 - Greater than 100 kW and less than 1 MW.



Two Different Applications

- Must submit a completed application to Distributor prior to purchasing any DG equipment.
- If the equipment meets the criteria for Tier 1, complete the application in Attachment 1.
- If the system meets the criteria of Tier 2 or 3, complete the application in Attachment 2.



Process

- Application is approved.
- System is Installed.
- Local jurisdiction performs inspection for compliance with NEC and any other applicable codes.
- After installation, the Customer returns the Certificate of Completion (Attachment 3) to the Distributor.

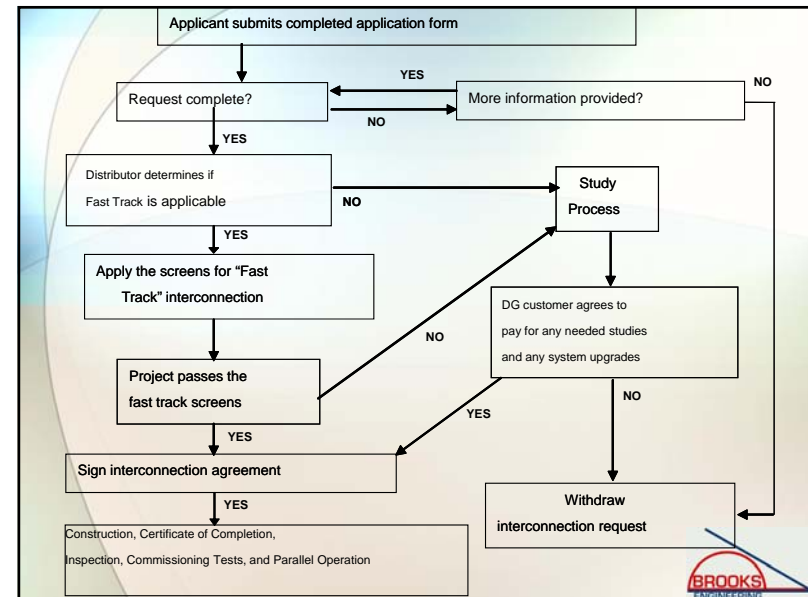

Completing the Process

- If the inspection of the completed system and any required Commissioning test are satisfactory, the Distributor will notify the Customer in writing that interconnection of the DG Equipment is authorized for parallel operation.



Standards Governing Interconnection

- IEEE1547 Standard for Interconnecting Distributed Resources with Electric Power Systems
- IEEE1547.1 Standard Conformance Test Procedures for Equipment Interconnecting Distributed Resources with Electric Power Systems
- UL 1741 Inverters, Converters, and Controllers for Use in Independent Power Systems
- NFPA 70 National Electrical Code



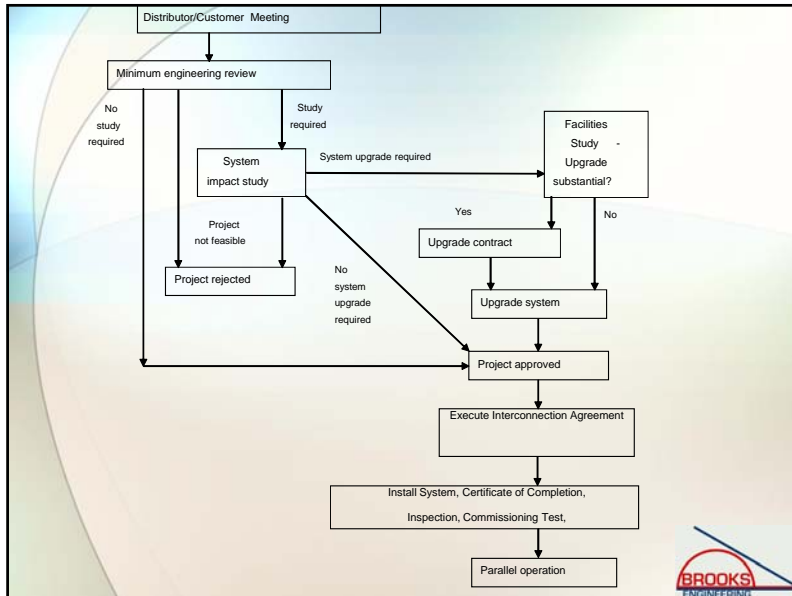

Summary of Key PV-Related Changes for the 2005 and 2008 National Electrical Code

- ### I. General [2008 NEC]
- #### 690.4 (D) Equipment Installation
- “Inverters, motor generators, photovoltaic modules, photovoltaic panels, ac photovoltaic modules, source-circuit combiners, and charge controllers intended for use in photovoltaic power systems shall be identified and listed for the application.”
 - Modules listed to UL1703 (soon UL1730); all combiners, controllers, and Inverters listed to UL1741
-

- ### I. General [2008 NEC]
- #### 690.5 Ground-Fault Protection
- “Grounded dc photovoltaic arrays shall be provided with dc ground-fault protection.”
 - *Exception No. 1: Ground-mounted or pole-mounted photovoltaic arrays with not more than two paralleled source circuits and with all dc source and dc output circuits isolated from buildings*
 - *Exception No. 2: PV arrays installed at other than dwelling units shall be permitted without ground-fault protection where the equipment grounding conductors are sized in accordance with 690.45.*
-

I. General [2008 NEC] 690.5 Ground-Fault Protection (cont.)

- “Manual operation of the main PV dc disconnect shall not activate the ground-fault protection device or result in grounded conductors becoming ungrounded.”
- GFP must either open all conductors or deenergize the inverter output.



I. General [2008 NEC] 690.5 (C) Labels and Markings

- Inverter and battery (if used) must have a sign
- A warning label shall appear on the utility-interactive inverter or be applied by the installer near the ground-fault indicator at a visible location, stating the following:
- WARNING, ELECTRIC SHOCK HAZARD, IF A GROUND FAULT IS INDICATED, NORMALLY GROUNDED CONDUCTORS, MAY BE UNGROUNDED AND ENERGIZED



II. Circuit Requirements [2008 NEC] 690.7 Maximum Voltage.

- New table and calculation option.
- Table 690.7 is now graduated in 4°C increments.
- “When open-circuit voltage temperature coefficients are supplied in the instructions for listed PV modules, they shall be used to calculate the maximum photovoltaic system voltage as required by 110.3(B) instead of using Table 690.7.”



II. Circuit Requirements [2008 NEC] 690.7 Maximum Voltage.

- Example Calculation
- Shell SQ-175PC has a Voc Temperature Coefficient in their literature of:
 - $\alpha_{Voc} = -129 \text{ mV}/^\circ\text{C}$; $V_{oc} = 44.6\text{V}$
 - Coldest expected Temp = -25°C ; Rating @ 25°C (STC)
- V_{max} (per module) = $44.6\text{V} + [-129 \text{ mV}/^\circ\text{C} \times (1\text{V}/1000\text{mV}) \times (-25^\circ\text{C} - 25^\circ\text{C})] = 51.05 \text{ Volts}$.
- Table 690.7 [2008]: $V_{max} = 44.6\text{V} \times 1.20 = 53.52\text{V}$
- Table 690.7 [2005]: $V_{max} = 44.6\text{V} \times 1.25 = 55.75\text{V}$



III. Disconnecting Means [2005 NEC]

Article 690.14 (Additional Provisions)

- Clarification on location of PV Disconnecting Means and Location of Inverters in Not-Readily-Accessible Locations
- New Section (D) Utility-Interactive Inverters Mounted in Not-Readily Accessible Locations. Utility-interactive inverters shall be permitted to be mounted on roofs or other exterior areas that are not readily accessible. These installations shall comply with (1) through (4):
 - (1) A direct-current photovoltaic disconnecting means shall be mounted within sight of or in the inverter.
 - (2) An alternating-current disconnecting means shall be mounted within sight of or in the inverter.
 - (3) The alternating-current output conductors from the inverter and an additional alternating-current disconnecting means for the inverter shall comply with 690.14(C)(1).
 - (4) A plaque shall be installed in accordance with 705.10.



Article 690.31 [2005 NEC] Wiring Methods Permitted

- New 690.31(E) related to PV Output Circuits in metallic raceways.
- “(E) Direct-Current Photovoltaic Source and Output Circuits Inside a Building. Where direct current photovoltaic source or output circuits of a utility-interactive inverter from a building-integrated or other photovoltaic system are run inside a building or structure, they shall be contained in metallic raceways or **metal** enclosures from the point of penetration of the surface of the building or structure to the first readily accessible disconnecting means. The disconnecting means shall comply with 690.14(A) through 690.14(D).”



Article 690.31 [2008 NEC] Wiring Methods Permitted

- New language in 690.31(A) “Where photovoltaic source and output circuits operating at maximum system voltages greater than 30 volts are installed in readily accessible locations, circuit conductors shall be installed in a raceway.”



Article 690.31 [2008 NEC] Wiring Methods Permitted

- New language in 690.31(B)
- “(B) Single-Conductor Cable. Single-conductor cable type USE-2, and single-conductor cable listed and labeled as photovoltaic (PV) wire shall be permitted in exposed outdoor locations in photovoltaic source circuits for photovoltaic module interconnections within the photovoltaic array. *Exception: Raceways shall be used when required by 690.31(A).*”



Article 690.31 [2005 NEC] Wiring Methods Permitted

- New Fine Print Note in 690.31(A)
 - “FPN: Photovoltaic modules operate at elevated temperatures when exposed to high ambient temperatures and to bright sunlight. These temperatures may routinely exceed 70° C (158° F) in many locations. Module interconnection conductors are available with insulation rated for wet locations and a temperature rating of 90° C (194° F) or greater.”



Side Note on Temperature 310.10 FPN No. 2 [2005 NEC]

- New Fine Print Note (below)
 - “FPN No. 2: Conductors installed in conduit exposed to direct sunlight in close proximity to rooftops have been shown, under certain conditions, to experience a temperature rise of 17° C (30° F) above ambient temperature on which the ampacity is based.”



Side Note on Temperature 310.15(B)(2)[2008 NEC]

- “(c) *Conduits Exposed to Sunlight on Rooftops.* Where conductors or cables are installed in conduits exposed to direct sunlight on or above rooftops, the adjustments shown in Table 310.15(B)(2)(c) shall be added to the outdoor temperature to determine the applicable ambient temperature for application of the correction factors in Table 310.16 and Table 310.18.
FPN: One source for the average ambient temperatures in various locations is the ASHRAE handbook – *Fundamentals.*”



Side Note on Temperature 310.15(B)(2)[2008 NEC]

- Table 310.15(B)(2)(c) Ambient Temperature Adjustment for Conduits Exposed to Sunlight On or Above Rooftops Temperature Adder
- | Distance Above Roof to Bottom of Conduit | °C °F |
|---|-------|
| 0 - 13 mm (1/2 in.) | 33 60 |
| Above 13 mm (1/2 in.) - 90 mm (3 1/2 in.) | 22 40 |
| Above 90 mm (3 1/2 in.) - 300 mm (12 in.) | 17 30 |
| Above 300 mm (12 in.) - 900 mm (36 in.) | 14 25 |



Article 690.31 [2008 NEC] Wiring Methods Permitted

- New language in 690.31(F)
- “(F) Flexible, Fine-Stranded Cables. Flexible, finestranded cables shall be terminated only with terminals, lugs, devices, or connectors that are identified and listed for such use.”



Article 690.33 [2008 NEC] Connectors

- New language in 690.33(F)
- “(E) Interruption of Circuit. Connectors shall be either (1) or (2):
- (1) Be rated for interrupting current without hazard to the operator.
- (2) Be a type that requires the use of a tool to open and marked “Do Not Disconnect Under Load” or “Not for Current Interrupting.” ”



Article 690.35 Ungrounded Photovoltaic Power Systems

- Ungrounded systems have not been prohibited, but the 2005 NEC was the first code cycle where the requirements are specifically called out.
- Included is an exception in 690.41 for consistency.



Article 690.35 Ungrounded Photovoltaic Power Systems [2005, 2008]

- “Photovoltaic power systems shall be permitted to operate with ungrounded photovoltaic source and output circuits where the system complies with 690.35(A) through 690.35(G).
- (A) Disconnects. All photovoltaic source and output circuit conductors shall have disconnects complying with 690, Part III.
- (B) Overcurrent Protection. All photovoltaic source and output circuit conductors shall have overcurrent protection complying with 690.9.
- (C) Ground-Fault Protection. All photovoltaic source and output circuits shall be provided with a ground-fault protection device or system that complies with (1) through (3):
 - (1) Detects a ground fault.
 - (2) Indicates that a ground fault has occurred
 - (3) Automatically disconnects all conductors or causes the inverter or charge controller connected to the faulted circuit to automatically cease supplying power to output circuits.



Article 690.35 Ungrounded Photovoltaic Power Systems (cont.)

- (D) The photovoltaic source and output conductors shall consist of the following:
 - (1) Nonmetallic jacketed multiconductor cables
 - (2) Conductors installed in raceways, or
 - (3) Conductors listed and identified as Photovoltaic (PV) Wire installed as exposed, single conductors.
- (E) The photovoltaic power system direct-current circuits shall be permitted to be used with ungrounded battery systems complying with 690.71(G).
- (F) The photovoltaic power source shall be labeled with the following warning at each junction box, combiner box, disconnect, and device where the ungrounded circuits may be exposed during service:

WARNING
ELECTRIC SHOCK HAZARD
THE DC CIRCUIT CONDUCTORS OF THIS
PHOTOVOLTAIC POWER SYSTEM ARE
UNGROUND **AND** MAY BE ENERGIZED
WITH RESPECT TO GROUND DUE TO
LEAKAGE PATHS AND/OR GROUND FAULTS.
- (G) The inverters or charge controllers used in systems with ungrounded photovoltaic source and output circuits shall be listed for the purpose.



Grounding—Numerous Changes in 2005 & 2008

- 690.42 Point of System Grounding Connection
- 690.43, .45, .46 Equipment Grounding
- Grounding Electrode Systems 690.47—Changed in 2005 and completely rewritten in 2008.
- 690.48 Continuity of Equipment Grounding Systems
- 690.49 Continuity of Photovoltaic Source and Output Circuit Grounded Conductors



690.42 Point of System Grounding Connection [2008 NEC]

- Misleading FPN needed more information:
 - *FPN: Locating the grounding connection point as close as practicable to the photovoltaic source better protects the system from voltage surges due to lightning.*
 - “Exception: Systems with a 690.5 ground-fault protection device shall be permitted to have the required grounded conductor-to-ground bond made by the ground-fault protection device. This bond, where internal to the ground-fault equipment, shall not be duplicated with an external connection.”



690.43 Equipment Grounding [2008 NEC]

- “Equipment grounding conductors for the PV array and structure (where installed) shall be contained within the same raceway or cable, or otherwise run with the PV array circuit conductors when those circuit conductors leave the vicinity of the PV array”



690.45 Size of Equipment Grounding Conductors [2008 NEC] (Size matters—or maybe not)

- “(A) General. Equipment grounding conductors in photovoltaic source and photovoltaic output circuits shall be sized in accordance with Table 250.122. Where no overcurrent protective device is used in the circuit, an assumed overcurrent device rated at the photovoltaic rated shortcircuit current shall be used in Table 250.122. Increases in equipment grounding conductor size to address voltage drop considerations shall not be required. The equipment grounding conductors shall be no smaller than 14 AWG.”



690.45 Size of Equipment Grounding Conductors [2008 NEC]

- “(B) Ground-Fault Protection Not Provided. For other than dwelling units where ground-fault protection is not provided in accordance with 690.5(A) through (C), each equipment grounding conductor shall have an ampacity of at least two (2) times the temperature and conduit fill corrected circuit conductor ampacity”
- Enjoy reading the FPN... Faults 3-5 series strings might not blow string fuse so EGC must be oversized when no GFP is provided—generally irrelevant.



690.46 Array Equipment Grounding Conductors. [2008 NEC]

- “Equipment grounding conductors for photovoltaic modules smaller than 6 AWG shall comply with 250.120(C).”
- This matches new language at the beginning of 690.43 that states, “An equipment grounding conductor between a PV array and other equipment shall be required in accordance with 250.110.”



690.47(C) Systems with Alternating-Current and Direct-Current Grounding Requirements [2005 NEC]

- “Photovoltaic power systems with both alternating-current and direct-current (dc) grounding requirements shall be permitted to be grounded as described in (1) or (2):
 - (1) A grounding-electrode conductor shall be connected between the identified dc grounding point to a separate dc grounding electrode. The dc grounding-electrode conductor shall be sized according to 250.166. The dc grounding electrode shall be bonded to the ac grounding electrode to make a grounding electrode system according to 250.52 and 250.53. The bonding conductor shall be no smaller than the largest grounding electrode conductor, either ac or dc.
 - (2) The dc grounding electrode conductor and ac grounding electrode conductor shall be connected to a single grounding electrode. The separate grounding electrode conductors shall be sized as required by 250.66 (ac) and 250.166 (dc).”



690.47(C) Systems with Alternating-Current and Direct-Current Grounding Requirements [2008 NEC]

- 2008 NEC has 8 qualifying provisions to “assist” in specifying the grounding requirements.
- Attempt is to reduce the required size of grounding electrode conductor for utility-interactive inverters with GFP.
- The requirements are difficult to follow and do not encourage straightforward enforcement of provisions.
- Some have expressed concern over using an equipment grounding conductor to serve the purpose of the grounding electrode conductor given the less-stringent fastening requirements of equipment grounds (2008 NEC Handbook).



690.47(D) Additional Electrodes for Array Grounding [2008 NEC]

- “Grounding electrodes shall be installed in accordance with 250.52 at the location of all ground- and pole-mounted photovoltaic arrays and as close as practicable to the location of roof-mounted photovoltaic arrays. The electrodes shall be connected directly to the array frame(s) or structure.”
 - GEC from array frames to electrode sized to 250.166
 - No substitute for equipment grounding conductor
 - Ground-mount structure meeting 250.52 complies
 - Roof-mounted may use building steel meeting 250.52(A)(2)
- Exception 1—Arrays with integral loads (area lights)
- Exception 2—If closer than 6’ from existing electrode



690.53 Marking: DC PV Power Source [2008 NEC]

- (1) Rated maximum power-point current
 - $I_{mp} \times \text{number of series strings}$
- (2) Rated maximum power-point voltage
 - $V_{mp} \times \text{number of modules in series}$
- (3) Maximum system voltage
 - FPN to (3): See 690.7(A) for maximum photovoltaic system voltage.
- (4) Short-circuit current
 - FPN to (4): See 690.8(A) for calculation of maximum circuit current.
- (5) Maximum rated output current of the charge controller (if installed)



Article 690.64 (B)(5) [2005 NEC]

- Clarification on not requiring individual clamping of circuit breakers for 690.60 (utility-interactive) inverters. Many inspectors will require clamps because they are not familiar with PV systems.
- “Circuit breakers, if backfed, shall be identified for such operation. Dedicated circuit breakers backfed from listed utility-interactive inverters complying with 690.60 shall not be required to be individually clamped to the panelboard bus bars. A front panel shall clamp all circuit breakers to the panelboard bus bars. Main circuit breakers connected directly to energized feeders shall also be individually clamped.”



2008 NEC Complete Rewrites Article 690.64 Point of Connection (B) Load Side

- “Where distribution equipment, including switchboards and panelboards, is fed simultaneously by a primary source(s) of electricity and one or more utility-interactive inverters, and where this distribution equipment is capable of supplying multiple branch circuits or feeders, or both, the interconnecting provisions for the utility-interactive inverter(s) shall comply with (B)(1) through (B)(7).”



Article 690.64(B) (cont.)

- “(1) Dedicated Overcurrent and Disconnect. Each source interconnection shall be made at a dedicated circuit breaker or fusible disconnecting means.
- (2) Bus or Conductor Rating. The sum of the ampere ratings of overcurrent devices in circuits supplying power to a busbar or conductor shall not exceed 120 percent of the rating of the busbar or conductor. In systems with panelboards connected in series, the rating of the first overcurrent device directly connected to the output of a utility-interactive inverter(s) shall be used in the calculations for all busbars and conductors.”



Article 690.64(B) (cont.)

- “(3) Ground-Fault Protection. The interconnection point shall be on the line side of all ground-fault protection equipment.
Exception: Connection shall be permitted to be made to the load side of ground-fault protection, provided that there is ground-fault protection for equipment from all ground-fault current sources. Ground-fault protection devices used with supplies connected to the load-side terminals shall be identified and listed as suitable for backfeeding.
- (4) Marking. Equipment containing overcurrent devices in circuits supplying power to a busbar or conductor supplied from multiple sources shall be marked to indicate the presence of all sources.”



Article 690.64(B) (cont.)

- (5) Suitable for Backfeed. Circuit breakers, if backfed, shall be suitable for such operation.
FPN: Circuit breakers that are marked “Line” and “Load” have been evaluated only in the direction marked. Circuit breakers without “Line” and “Load” have been evaluated in both directions.
- (6) Fastening. Listed plug-in-type circuit breakers backfed from utility-interactive inverters complying with 690.60 shall be permitted to omit the additional fastener normally required by 408.36(D) for such applications.”



Article 690.64(B) (cont.)

- “(7) Inverter Output Connection. Unless the panelboard is rated not less than the sum of the ampere ratings of all overcurrent devices supplying it, a connection in a panelboard shall be positioned at the opposite (load) end from the input feeder location or main circuit location. The bus or conductor rating shall be sized for the loads connected in accordance with Article 220. A permanent warning label shall be applied to the distribution equipment with the following or equivalent marking:

WARNING

INVERTER OUTPUT CONNECTION, DO NOT RELOCATE, THIS OVERCURRENT DEVICE”



Field Inspection



Equipment, conduit, and wiring installed according to plans

- PV module model number matches plans and cut sheets
- PV modules are properly grounded with lugs on each module and mounting rails or some equivalent grounding method.

Wrong connectors

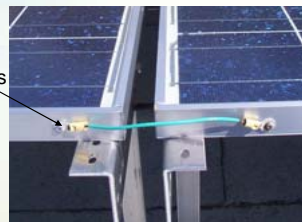

Wire Management



Wire Management

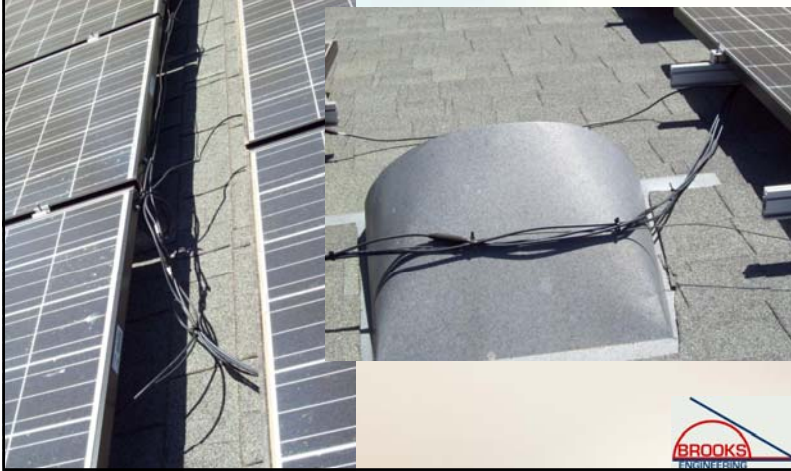

Wire Management



Wire Management



Wire Management

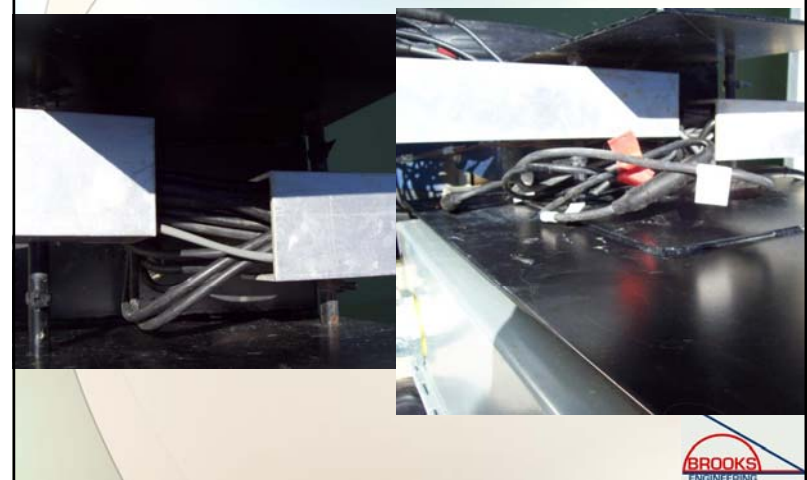



What you can't see won't hurt you??



Support Structure and Attachment



Structure attached according to plans and directions



Support Structure and Attachment



Support Structure and Attachment



Support Structure and Attachment

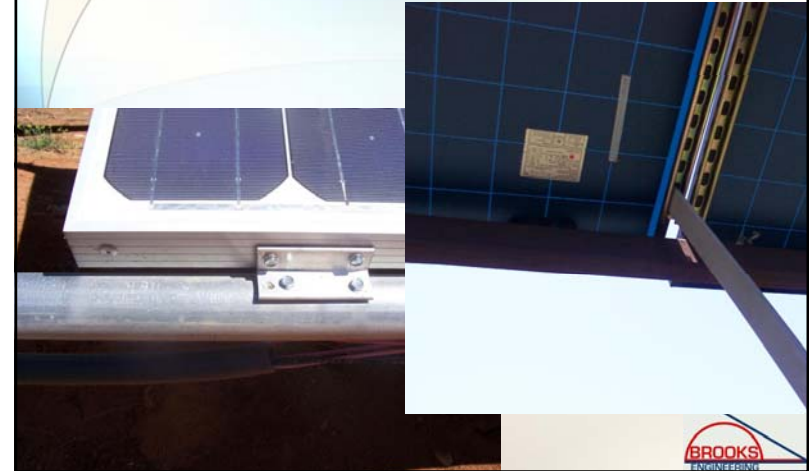

Support Structure and Attachment



Support Structure and Attachment



Hardware and Components



Hardware and Components



Hardware and Components



Hardware and Components



Equipment, conduit, and wiring installed according to plans

- Check that wiring is consistent with callouts on plans (number and type of modules, correct fuses)
- Check that cable and conduit is properly supported
- Where plug connectors are used for module wiring, inspect a sample of the connections to make sure that connectors are fully engaged



Correct Fuses

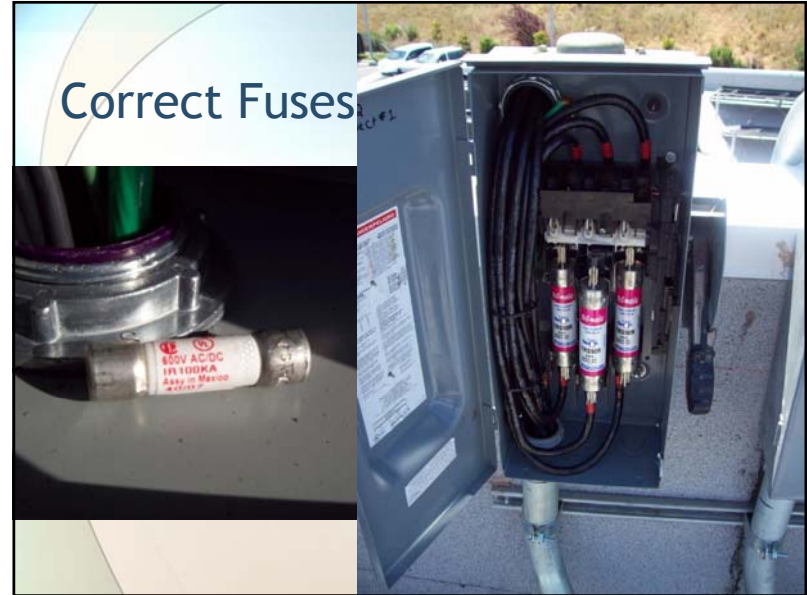

Correct Fuses



Correct Fuses ??

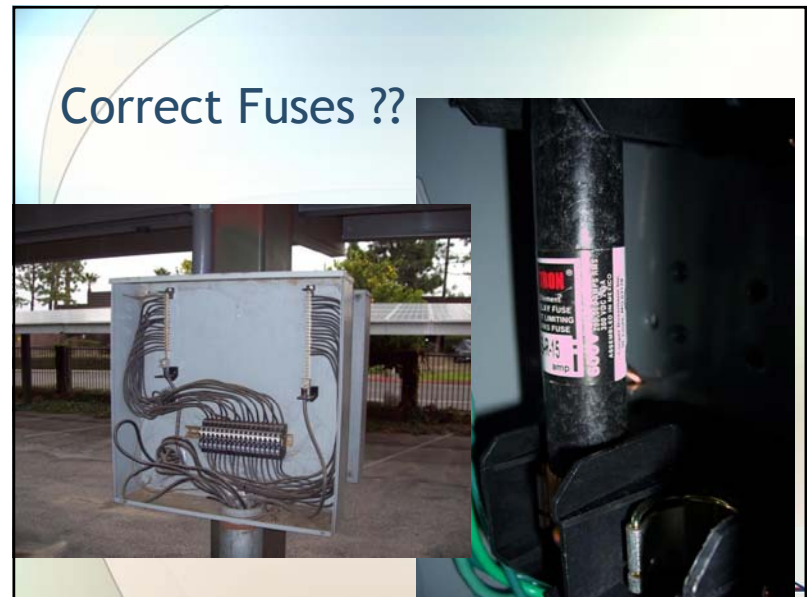

Correct Fuses ??

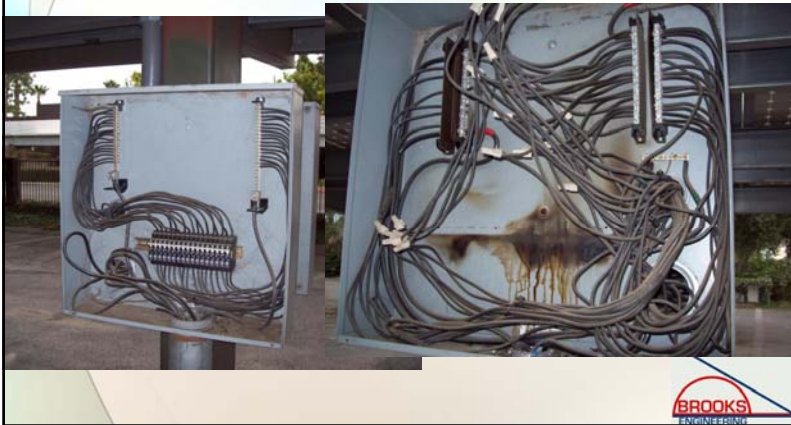

Correct Fuses and Terminals ?

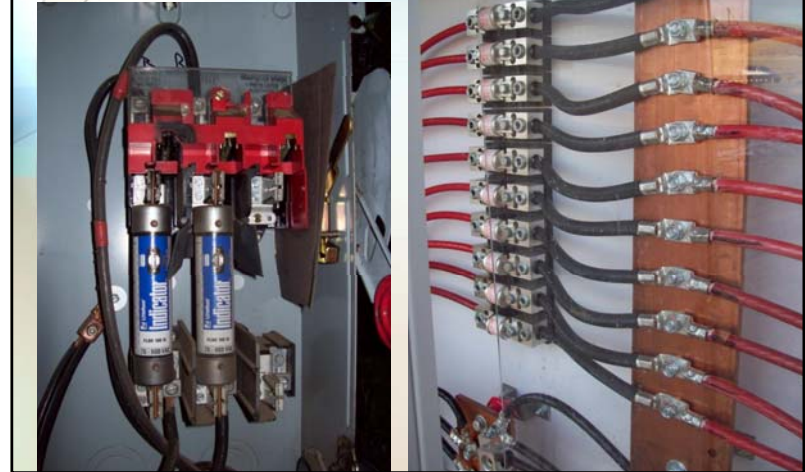

Properly Rated?



Properly Rated?

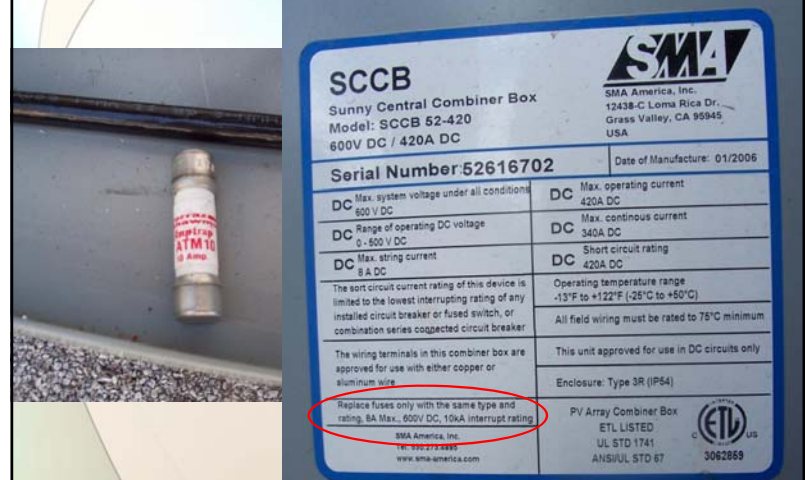

Properly Rated Disconnects and Inverters



Properly Rated Disconnects and Inverters



Properly Rated Disconnects and Inverters



Properly Rated Conductors



Appropriate signs installed

- Sign construction
- Photovoltaic Power Source
- AC point of connection
- inverter matches one-line
- alternative power system
- Optional Standby System
(if battery-backed unit)

WAREHOUSE

PV POWER SOURCE
DC RATINGS

STANDING TEST CONDITIONS
CELL TEMPERATURE = 25°C
IRRADIANCE = 1000 W/m²

OPERATING DC CURRENT	53.6	Amps
OPERATING DC VOLTAGE	415	Volts
OPERATING DC POWER	23,740	Watts
MAXIMUM SYSTEM DC VOLTAGE	600	Volts
SHORT-CIRCUIT DC CURRENT	65.2	Amps

SCHOTT



Signs and Labels



Signs and Labels

WAREHOUSE

PV POWER SOURCE
DC RATINGS

STANDING TEST CONDITIONS
CELL TEMPERATURE = 25°C
IRRADIANCE = 1000 W/m²

OPERATING DC CURRENT	53.6	Amps
OPERATING DC VOLTAGE	415	Volts
OPERATING DC POWER	23,740	Watts
MAXIMUM SYSTEM DC VOLTAGE	600	Volts
SHORT-CIRCUIT DC CURRENT	65.2	Amps

SCHOTT

PHOTOVOLTAIC DC DISCONNECT
WARNING! ELECTRIC SHOCK HAZARD!

Voc	542 V
Vmp	392 V
Isc	504 A
Isc	471 A

SolarCity (888) SOL-CITY
WWW.SOLARCITY.COM



Signs and Labels



Signs and Labels



VISIBLE - BLADE
UTILITY
AC DISCONNECT

INTERACTIVE SYSTEM
POINT OF INTERCONNECTION
OPERATING AC CURRENT
54.1A
OPERATING VOLTAGE
480V

Signs and Labels



Signs and Labels

Sunny Boy Utility Interactive 1-Phase Inverter SB6000U

Tested To Comply With FCC Standards FOR HOME OR OFFICE USE

Serial Number: 2000105773 Date of manufacture: 01/2005

AC Max. continuous output power* 3000 W	AC Max. utility backfeed current 20 A
AC Operating voltage range (Vdc) MIN 183 NOMINAL 208 MAX 229	DC Max system voltage under all conditions 600 V
AC Operating frequency range (Hz) MIN 59.3 NOMINAL 60.0 MAX 60.5	DC Range of operating DC voltage 250 - 480 Vdc (at Vacuum)
AC Max. continuous output current 25 A RMS (22 A @ 277V AC)	DC Max. operating current 25 A
AC Max. output fault current 25 A	DC Max. array short circuit current 37.5 A
AC Max. branch circuit overcurrent protection 40 A	DC Max. array short circuit current 37.5 A

* For more details, see the Operator's Manual

SMA America Inc. phone: 530.273.4895 www.sma-america.com

ENCLOSURE Type 3R (IP54)

UL US LISTED Utility interactive inverter LISTED UL 1741 36AN

xantrex Smart Choice for Power

181-G South Vason Rd., Livermore, CA USA

LISTED UTILITY INTERACTIVE 3 PHASE INVERTER

DC Max. system DC voltage 600V	AC Max. input current 300ma
DC Max. operating current 95.7A	AC Open Volt. range 167-275 V-L
DC Range of oper. with 120-480V	AC Oper. freq. range 59.3 - 60.5
DC Max. array short circuit current 130A	AC Normal output freq. 60 Hz
AC Nominal output voltage 208V	AC Max. output overcurrent protection 135A
AC Maximum utility backfeed current 20A	AC Maximum output fault current 30A
AC Maximum output current 25A	AC Max. continuous output power 30 kVA

MANUFACTURED IN CHINA

1188

Guts—show and tell



Guts—show and tell

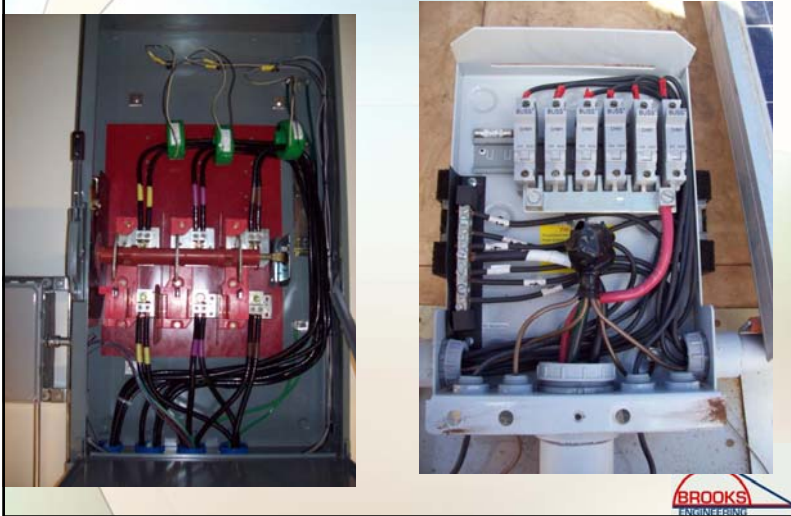

Guts—show and tell

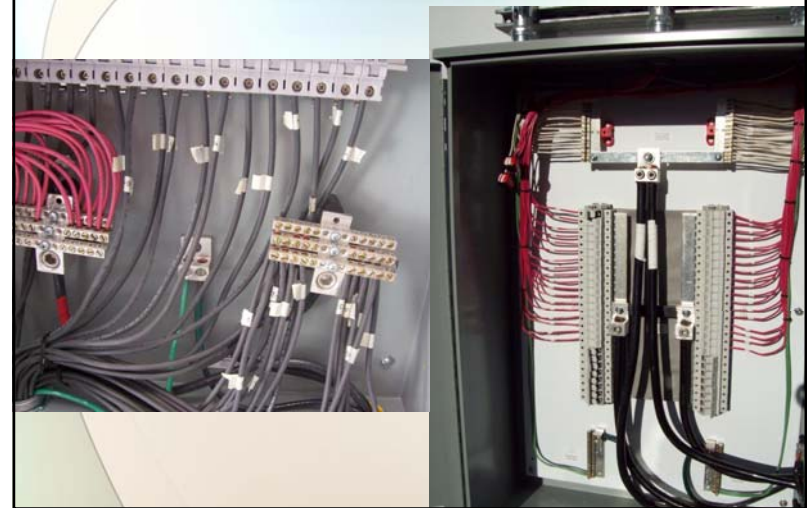

Guts—show and tell



Guts—show and tell



Good Installation Practices



Good Installation Practices



Good Installation Practices



Good Installation Practices



Good Installation Practices

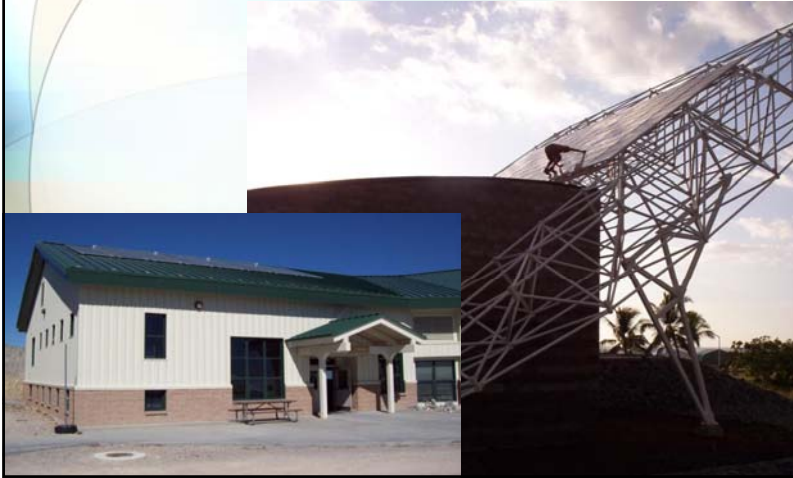

Nice Work



Nice Work



Nice Work



Nice Work



Nice Work



Nice Work



Nice Work



What are the next steps needed to propagate these practices?

- A guideline is not law and must be adopted voluntarily by the AHJ.
- Influential building officials and chief electrical inspectors need to understand what is needed for safe PV installations, provide feedback to these guidelines, and then incorporate them into their standard practices.
- Articles in code official newsletters can help spread the word that these guidelines are available and are being used by jurisdictions.



Expedited Permit Process for PV Systems

with Detailed Explanation to Help Guide Thru the Process

Prepared for:

New Mexico State University
Solar America Board for Codes and Standards
(available at www.SolarABCS.org)

Prepared by:

Brooks Engineering
873 Kells Circle
Vacaville, CA 95688
www.brooksolar.com



Version 4
May 2009

Dedication:

This document is dedicated to two key individuals that represent the very best of those who have worked on the codes and standards processes as they relate to PV systems. These two amazing people, Tim Owens, of Santa Clara Building Department, and Chuck Whitaker, of BEW Engineering, passed away in the months prior to the release of this standardized permitting process.

Tim Owens:

Tim Owens passed away in December of 2008 at the age of ?? in the midst of a distinguished career in the electrical trades and code enforcement. While working as Chief Electrical Inspector for the City of San Diego in 1999, Tim was the first jurisdictional officer to put together a simplified permitting process for PV systems. His desire to see such a process become commonplace is what has driven this author to work on improving permitting and approval processes for PV systems for the past decade. The solar community, lost a true friend and partner who was dedicated to the success of solar photovoltaic systems in California and the rest of the U.S.

Chuck Whitaker:

Chuck Whitaker passed away in early May of 2009 at the age of 50 in the midst of a distinguished career supporting the development and implementation of most of the codes and standards the govern and support PV systems both nationally and internationally. His passing coincided with the initial release of this standardized permitting process. The author had the privilege of knowing Chuck for two decades and working closely with him for over 8 years as his employee and colleague. It is difficult to overstate Chuck's contribution to the PV industry since his influence is found in nearly every code and standard that has been developed for PV equipment and systems over the past 25 years. It is only fitting that this document, which includes his influence, be dedicated to his memory. A huge hole is left in the PV industry with Chuck's passing, and it is the hope of many of us in the codes and standards arena to be able to carry on his tireless work with a semblance of the skill, wit, and humor that was the hallmark of this amazing individual.

INTRODUCTION:	3
Expedited Permit Process for Small-Scale PV Systems	4
Expedited Permit Guidelines for Small-Scale PV Systems	8
Section 1. Required Information for Permit:	8
Section 2. Step 1: Structural Review of PV Array Mounting System	8
Section 3. Step 2: Electrical Review of PV System (Calculations for Electrical Diagram)	10
Section 4. Inverter Information	11
Section 5. Module Information.....	12
Section 6. Array information	13
a) NUMBER OF MODULES IN SERIES.....	13
b) NUMBER OF PARALLEL CIRCUITS.....	13
c) LOWEST EXPECTED AMBIENT TEMP.....	13
d) HIGHEST CONTINUOUS TEMP (ambient).....	13
Section 7. SIGNS.....	14
a) PV POWER SOURCE.....	14
b) WARNING SIGN REQUIRED BY <i>NEC</i> 690.17.	15
c) Point of Connection Sign [<i>NEC</i> 690.54].....	15
Section 8. Wiring and Overcurrent Protection	16
a) DC Wiring Systems:	16
b) AC Wiring Systems	18
Section 9. AC Point of Connection	18
Section 10. Grounding	19
a) System Grounding.....	19
b) Equipment Grounding.....	19
c) Sizing of Grounding Conductors	20
APPENDIX	21
APPENDIX A: EXAMPLE SUBMITTAL	22
APPENDIX B: STRUCTURAL	26
STRUCTURE WORKSHEET WKS1	26
B.2 SPAN TABLES.....	27
Span Table R802.5.1(1),	27
Span Table R802.5.1(2),	28
APPENDIX C: SPECIAL ELECTRICAL TOPICS	29
Module Frame Grounding:	29
AC Connection to Building Electrical Systems	30
AC Connection to Load Side of Main Service Panel.....	30
AC Connection to Subpanel:	31
AC Supply Side Connection:	32
Source Circuit Overcurrent Protection:	33
Disconnecting Means:.....	34
Provisions for the photovoltaic power source disconnecting means:	35
APPENDIX D: COSTS OF PERMITS	36
APPENDIX E: TEMPERATURE TABLES	37

INTRODUCTION:

The one-page expedited permit process, and the accompanying document explaining each step, provides a means to differentiate systems that can be permitted quickly and easily due to their similarity with the majority of small-scale PV systems. As most systems have unique characteristics, they may be handled with small additions to this expedited process or may require much more information, depending on the uniqueness of the installation.

The diagrams shown in the Expedited Permit Process are available online at www.solarabcs.org in an interactive PDF format so that the diagrams can be filled out electronically and submitted either in printed form or via email to the local jurisdiction. An electronic format is used so that the supplied information is standardized and legible for the local jurisdiction. Additional drawings will be added to the website as they become available.

The expedited process does provide for flexibility in the structural review including span tables and additional information found in Appendix B of this explanatory document. PV systems with battery backup may be able to use a portion of this information to assist the permitting process, but array configurations and the battery system require a more detailed electrical drawing than this process provides.

The appendix to this explanatory document has an example submittal in Appendix A also has a variety of special electrical topics in Appendix C. It also includes temperature tables in Appendix D that are used in applying the National Electrical Code's temperature-dependent criteria. This document is intended to be usable throughout the United States and can provide standard installation design documentation for most locations within the U.S. and other regions that use the National Electrical Code.

Expedited Permit Process for Small-Scale PV Systems

The information in this guideline is intended to help local jurisdictions and contractors identify when PV system installations are simple, needing only a basic review, and when an installation is more complex. It is likely that 50%-75% of all residential systems will comply with these simple criteria. For projects that fail to meet the simple criteria, a resolution steps may be suggested to provide a path to permit approval.

Required Information for Permit:

1. Site plan showing location of major components on the property. This drawing need not be exactly to scale, but it should represent relative location of components at site (see supplied example site plan). PV arrays on dwellings with a 3' perimeter space at ridge and sides may not need separate fire service review.
2. Electrical diagram showing PV array configuration, wiring system, overcurrent protection, inverter, disconnects, required signs, and ac connection to building (see supplied standard electrical diagram).
3. Specification sheets and installation manuals (if available) for all manufactured components including, but not limited to, PV modules, inverter(s), combiner box, disconnects, and mounting system.

Step 1: Structural Review of PV Array Mounting System

Is the array to be mounted on a defined, permitted roof structure? Yes No

If No due to non-compliant roof or a ground mount, submit completed worksheet for the structure WKS1.

Roof Information:

1. Is the roofing type lightweight (Yes = composition, lightweight masonry, metal, etc...) _____
If No, submit completed worksheet for roof structure WKS1 (No = heavy masonry, slate, etc...).
2. Does the roof have a single roof covering? Yes No
If No, submit completed worksheet for roof structure WKS1.
3. Provide method and type of weatherproofing roof penetrations (e.g. flashing, caulk). _____

Mounting System Information:

1. The mounting structure is an engineered product designed to mount PV modules? Yes No
If No, provide details of structural attachment certified by a design professional.
2. For manufactured mounting systems, fill out information on the mounting system below:
 - a. Mounting System Manufacturer _____ Product Name and Model# _____
 - b. Total Weight of PV Modules and Rails _____ lbs
 - c. Total Number of Attachment Points _____
 - d. Weight per Attachment Point (b÷c) _____ lbs (if greater than 40 lbs, see WKS1)
 - e. Maximum Spacing Between Attachment Points on a Rail _____ inches (see product manual for maximum spacing allowed based on maximum design wind speed)
 - f. Total Surface Area of PV Modules (square feet) _____ ft²
 - g. Distributed Weight of PV Module on Roof (b÷f) _____ lbs/ft²
If distributed weight of the PV system is greater than 5 lbs/ft², see WKS1.

Step 2: Electrical Review of PV System (Calculations for Electrical Diagram)

In order for a PV system to be considered for an expedited permit process, the following must apply:

1. PV modules, utility-interactive inverters, and combiner boxes are identified for use in PV systems.
2. The PV array is composed of 4 series strings or less per inverter, and 15 kW_{STC} or less.
3. The total inverter capacity has a continuous power output 13,440 Watts or less
4. The ac interconnection point is on the load side of service disconnecting means (690.64(B)).
5. The electrical diagram (E1.1) can be used to accurately represent the PV system.

Fill out the standard electrical diagram completely. A guide to the electrical diagram is provided to help the applicant understand each blank to fill in. If the electrical system is more complex than the standard electrical diagram can effectively communicate, provide an alternative diagram with appropriate detail.

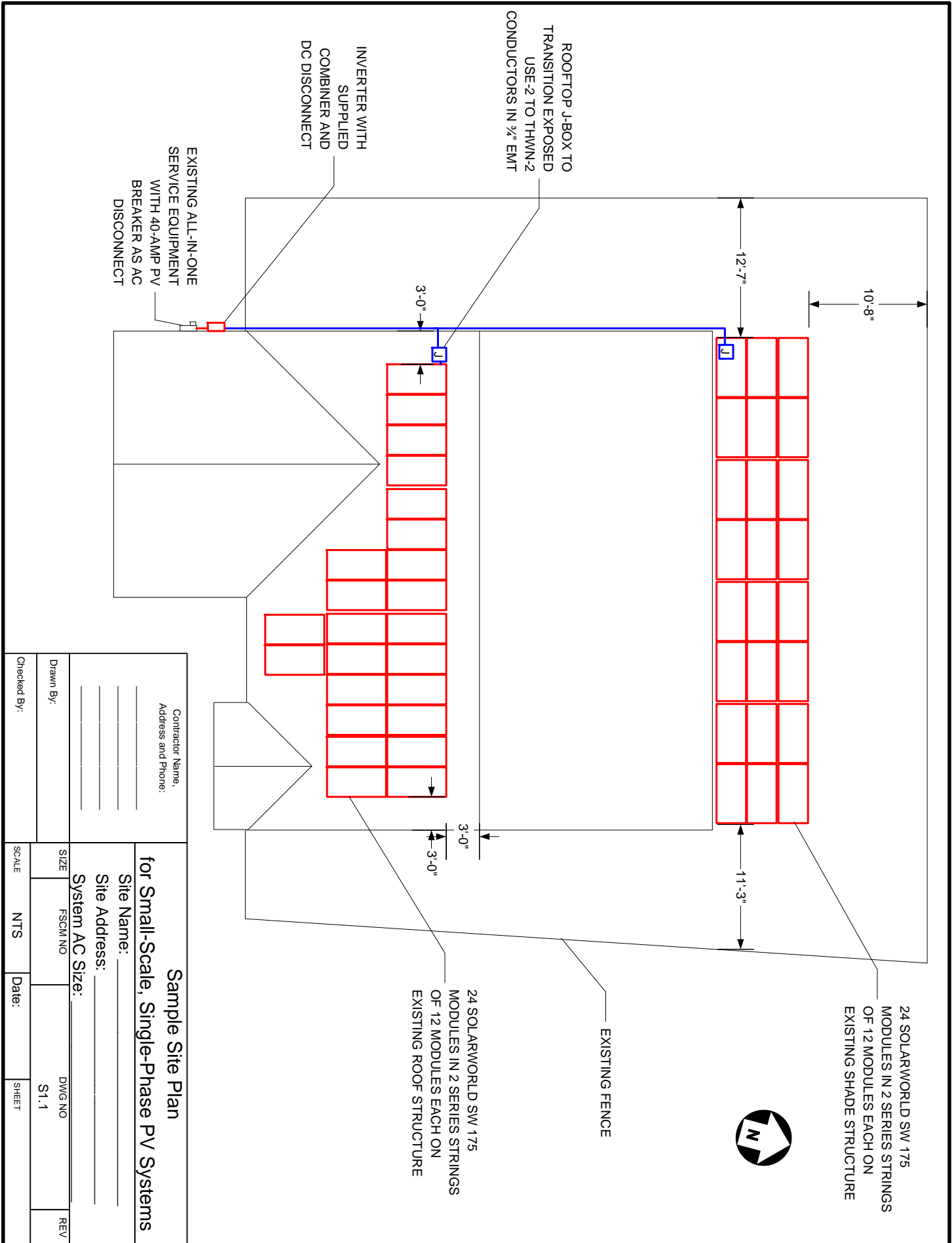

24 SOLARWORLD SW 175
 MODULES IN 2 SERIES STRINGS
 OF 12 MODULES EACH ON
 EXISTING SHADE STRUCTURE



EXISTING FENCE

24 SOLARWORLD SW 175
 MODULES IN 2 SERIES STRINGS
 OF 12 MODULES EACH ON
 EXISTING ROOF STRUCTURE

ROOFTOP J-BOX TO
 TRANSITION EXPOSED
 USE 2 TO THWN-2
 CONDUCTORS IN 3/4" EMT

INVERTER WITH
 SUPPLIED
 COMBINER AND
 DC DISCONNECT

EXISTING ALL-IN-ONE
 SERVICE EQUIPMENT
 WITH 40-AMP PV
 BREAKER AS AC
 DISCONNECT

Contractor Name:
 Address and Phone:

**Sample Site Plan
 for Small-Scale, Single-Phase PV Systems**

Site Name: _____
 Site Address: _____
 System AC Size: _____

Drawn By: _____
 Checked By: _____

SIZE	FSCM NO	DWG NO	REV
NTS		S1.1	
SCALE	Date:	SHEET	



EQUIPMENT SCHEDULE

TAG	DESCRIPTION	PART NUMBER	NOTES
1	SOLAR PV MODULE		
2	PV ARRAY		
3	J-BOX (IF USED)		
4	COMBINER (IF USED)		
5	DC DISCONNECT		
6	DC/AC INVERTER		
7	GEN METER (IF USED)		
8	AC DISCONNECT (IF USED)		
9	SERVICE PANEL		

VAC. _____ A MAIN. _____ A BUS. _____ A INVERTER OCPD
(SEE NOTE 5 FOR INVERTER OCPDs, ALSO SEE GUIDE SECTION 9)

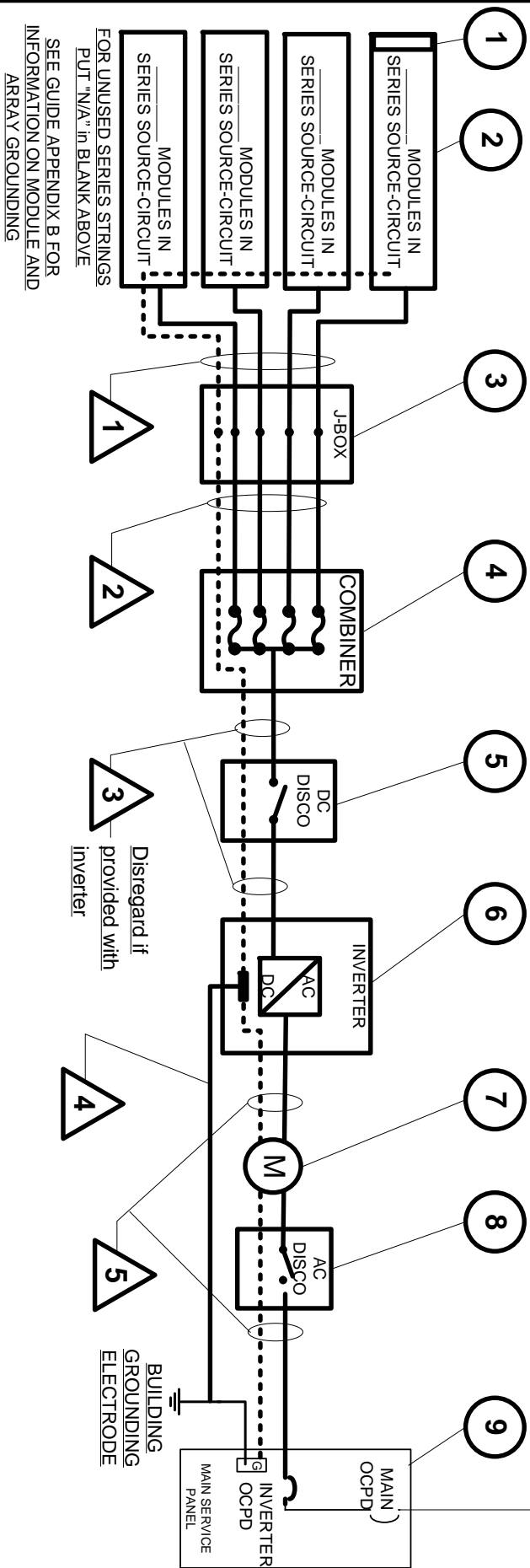

CONDUIT AND CONDUCTOR SCHEDULE

TAG	DESCRIPTION OR CONDUCTOR TYPE	COND. GAUGE	NUMBER OF CONDUCTORS	CONDUIT TYPE	CONDUIT SIZE
1	USE-2 <input type="checkbox"/> or PV WIRE <input type="checkbox"/>			N/A	N/A
2	BARE COPPER EQ. GRD. COND. (EGC)			N/A	N/A
3	THWN-2 <input type="checkbox"/> or XHHW-2 <input type="checkbox"/> or RHW-2 <input type="checkbox"/>				
4	INSULATED EGC				
5	DC GROUNDING ELECTRODE COND.				
6	THWN-2 <input type="checkbox"/> or XHHW-2 <input type="checkbox"/> or RHW-2 <input type="checkbox"/>				
7	INSULATED EGC				

Contractor Name, Address and Phone:

One-Line Standard Electrical Diagram for Small-Scale, Single-Phase PV Systems

Site Name:

Site Address:

System AC Size:

Drawn By:

SIZE

FSCM NO

DWG NO

REV

Checked By:

SCALE

NTS

Date:

SHEET

SIGNS-SEE GUIDE SECTION 7

NOTES FOR ALL DRAWINGS:

OCPPD = OVERCURRENT PROTECTION DEVICE
 NATIONAL ELECTRICAL CODE® REFERENCES
 SHOWN AS (NEC XXX.XX)

SIGN FOR DC DISCONNECT

PHOTOVOLTAIC POWER SOURCE	
RATED MPP CURRENT	A
RATED MPP VOLTAGE	V
MAX SYSTEM VOLTAGE	V
MAX CIRCUIT CURRENT	A
WARNING: ELECTRICAL SHOCK HAZARD-LINE AND LOAD MAY BE ENERGIZED IN OPEN POSITION	

SIGN FOR INVERTER OCPD AND AC DISCONNECT (IF USED)

SOLAR PV SYSTEM	
AC POINT OF CONNECTION	
AC OUTPUT CURRENT	A
NOMINAL AC VOLTAGE	V
THIS PANEL FED BY MULTIPLE SOURCES (UTILITY AND SOLAR)	

PV MODULE RATINGS @ STC (Guide Section 5)

MODULE MAKE	
MODULE MODEL	
MAX POWER-POINT CURRENT (I _{MPP})	A
MAX POWER-POINT VOLTAGE (V _{MPP})	V
OPEN-CIRCUIT VOLTAGE (V _{OC})	V
SHORT-CIRCUIT CURRENT (I _{SC})	A
MAX SERIES FUSE (OCPPD)	A
MAXIMUM POWER (P _{MAX})	W
MAX VOLTAGE (TYP 600V _{DC})	V
VOC TEMP COEFF (mV/°C <input type="checkbox"/> or %/°C <input type="checkbox"/>)	
IF COEFF SUPPLIED, CIRCLE UNITS	

INVERTER RATINGS (Guide Section 4)

INVERTER MAKE	
INVERTER MODEL	
MAX DC VOLT RATING	V
MAX POWER @ 40°C	W
NOMINAL AC VOLTAGE	V
MAX AC CURRENT	A
MAX OCPD RATING	A

NOTES FOR ARRAY CIRCUIT WIRING (Guide Section 6 and 8 and Appendix D):

- 1.) LOWEST EXPECT AMBIENT TEMPERATURE BASED ON ASHRAE MINIMUM MEAN EXTREME DRY BULB TEMPERATURE FOR ASHRAE LOCATION MOST SIMILAR TO INSTALLATION LOCATION. LOWEST EXPECTED AMBIENT TEMP ____°C
- 2.) HIGHEST CONTINUOUS AMBIENT TEMPERATURE BASED ON ASHRAE HIGHEST MONTH 2% DRY BULB TEMPERATURE FOR ASHRAE LOCATION MOST SIMILAR TO INSTALLATION LOCATION. HIGHEST CONTINUOUS TEMPERATURE ____°C
- 2.) 2005 ASHRAE FUNDAMENTALS 2% DESIGN TEMPERATURES DO NOT EXCEED 47°C IN THE UNITED STATES (PALM SPRINGS, CALS 44.1°C). FOR LESS THAN 9 CURRENT-CARRYING CONDUCTORS IN ROOF-MOUNTED SUNLIT CONDUIT AT LEAST 0.5" ABOVE ROOF AND USING THE OUTDOOR DESIGN TEMPERATURE OF 47°C OR LESS (ALL OF UNITED STATES),
 - a) 12 AWG, 90°C CONDUCTORS ARE GENERALLY ACCEPTABLE FOR MODULES WITH I_{SC} OF 7.68 AMPS OR LESS WHEN PROTECTED BY A 12-AMP OR SMALLER FUSE.
 - b) 10 AWG, 90°C CONDUCTORS ARE GENERALLY ACCEPTABLE FOR MODULES WITH I_{SC} OF 9.6 AMPS OR LESS WHEN PROTECTED BY A 15-AMP OR SMALLER FUSE.

NOTES FOR INVERTER CIRCUITS (Guide Section 8 and 9):

- 1) IF UTILITY REQUIRES A VISIBLE-BREAK SWITCH, DOES THIS SWITCH MEET THE REQUIREMENT? YES NO N/A
- 2) IF GENERATION METER REQUIRED, DOES THIS METER SOCKET MEET THE REQUIREMENT? YES NO N/A
- 3) SIZE PHOTOVOLTAIC POWER SOURCE (DC) CONDUCTORS BASED ON MAX CURRENT ON NEC 690.53 SIGN OR OCPD RATING AT DISCONNECT
- 4) SIZE INVERTER OUTPUT CIRCUIT (AC) CONDUCTORS ACCORDING TO INVERTER OCPD AMPERE RATING. (See Guide Section 9)
- 5) TOTAL OF _____ INVERTER OCPD(S). ONE FOR EACH INVERTER. DOES TOTAL SUPPLY BREAKERS COMPLY WITH 120% BUSBAR EXCEPTION IN 690.64(B)(2)(a)? YES NO

Notes for One-Line Standard Electrical Diagram for Single-Phase PV Systems

Contractor Name:
 Address and Phone:

Site Name: _____
 Site Address: _____
 System AC Size: _____

Drawn By:	SIZE	FSCOM NO	DWG NO	REV
Checked By:	SCALE	NTS	Date:	SHEET

Expedited Permit Guidelines for Small-Scale PV Systems

Section 1. Required Information for Permit:

1. Site plan showing location of major components on the property. This drawing need not be to scale, but it should represent relative location of components at site. (see supplied example site plan).

Explanation: This is a simple diagram to show where the equipment is located on the property. This can be a zone clearance plot plan with the equipment clearly shown and identified on the plan. If PV array is ground-mounted, clearly show that system will be mounted within allowable zoned setbacks. See site plan example drawing in permit process for reference.

2. Electrical diagram showing PV array configuration, wiring system, overcurrent protection, inverter, disconnects, required signs, and ac connection to building (see supplied standard electrical diagram).

Explanation: The cornerstone of a simplified permit process is the ability to express the electrical design with a generic electrical diagram. This diagram has been designed to accurately represent the majority of single-phase, residential-sized, PV systems. PV systems may vary dramatically in PV array layout and inverter selection. However, the majority of small-scale, residential-sized PV systems can be accurately represented by this diagram. This diagram must be fully completed filled out in order for the permit package to be submitted.

3. Specification sheets and installation manuals (if available) for all manufactured components including, but not limited to, PV modules, inverter(s), combiner box, disconnects, and mounting system.

Explanation: At a minimum, specification sheets must be provided for all major components. In addition to the components listed, other important components may be specialty fuses, circuit breakers, or any other unique product that may need to be reviewed by the local jurisdiction. Installation manuals are also listed in this item. This is referring to the brief versions of manuals that are reviewed by the listing agency certifying the product. Some detailed installation manuals can be several dozens or hundreds of pages. If the local jurisdiction feels it is necessary to review these large documents, a good alternative would be for the documents to be supplied electronically, rather than in print. It is worth consideration that PDFs of these comprehensive manuals be kept electronically by the local jurisdiction.

Section 2. Step 1: Structural Review of PV Array Mounting System

Is the array to be mounted on a defined, permitted roof structure? Yes No (structure meets modern codes)

If No, submit completed worksheet for roof structure WKS1.

Explanation: The reference to a defined, permitted roof structure refers to structures that have a clear inspection history so that verification of structural elements is unnecessary. If structural modifications have been made due to remodeling, those changes should be documented through the permit and review process. It also recognizes the fact that the code enforcement of roof structural elements has been much more consistent across the United States in the last 35 years. However, there may be many local jurisdictions who have been carefully reviewing roof structures for a much longer period of time. The local jurisdiction should consider extending this limit based on the period that roofs have been consistently inspected. In areas where jurisdictional reviews have not extended 35 years into

the past, the jurisdiction may need to get the information from WKS1 to be sure whether or not the proposed PV system is being installed on a typical roof structure or not.

Roof Information:

1. Is the roofing type lightweight (Yes = composition, lightweight masonry, metal, wood shake, etc...)_____
If No, submit completed worksheet for roof structure WKS1 (No = heavy masonry, slate, etc...).

Explanation: There is a need to distinguish if a roof has a lightweight product. Heavier roofing materials (e.g. slate, heavy masonry, may not have the assumed dead loading and live loading capacities that are found with lighter weight roofing materials. These are much less common roof types and often justify a further review to clarify that the roof structure is either in compliance or needs enhancement.

2. Does the roof have a single roof covering? Yes No

If No, submit completed worksheet for roof structure WKS1.

Explanation: Multiple composition roof layers are taking a portion or all of the assumed additional weight allowance found in the 5 lbs/ft² allowance at the end of the mounting system section.

3. Provide method and type of weatherproofing roof penetrations (e.g. flashing, caulk)._____

Explanation: The weatherproofing method needs to be specifically identified so that plan checkers and field inspectors are notified ahead of time of the method being used. Some jurisdictions may constrain weatherproofing methods and materials.

Mounting System Information:

1. The mounting structure is an engineered product designed to mount PV modules? Yes No

If No, provide details of structural attachment certified by a design professional.

Explanation: Non-engineered racking systems have undefined capabilities. PV systems should only be mounted using systems that are engineered and designed for that purpose. However, if an installer chooses to use a hybrid mounting system, then the system cannot be considered for expedited permitting.

2. For manufactured mounting systems, fill out information on the mounting system below:

- a. Mounting System Manufacturer _____ Product Name and Model# _____ (self-explanatory)
- b. Total Weight of PV Modules and Rails _____ lbs (include total weight of all hardware used along with module weight)
- c. Total Number of Attachment Points _____ (self-explanatory)
- d. Weight per Attachment Point (b÷c) _____ lbs (if greater than 40 lbs, see WKS1)

Explanation: 40 lbs has been used by many jurisdictions as a reasonable level below which point loading of roof joists and trusses can be ignored. Most standard mounting systems have point loadings of 25-35 lbs per attachment.

- e. Maximum Spacing Between Attachment Points on a Rail _____ inches
(see product manual for maximum spacing allowed based on wind loading)

Explanation: Depending on the wind loading requirements of a particular jurisdiction, the spacing or attachments may be dictated by the manufacturer's directions. For instance, a particular manufacturer may allow a 72" attachment spacing for a 90 MPH windspeed design, but the spacing reduces to a maximum of 48" when the design windspeed exceeds 100 MPH.

- f. Total Surface Area of PV Modules (square feet) _____ ft²

Explanation: Take the surface area of a single module, and multiply it by the total number of modules in the roof-mounted system.

- g. Distributed Weight of PV Module on Roof (b÷f) _____ lbs/ft²

If distributed weight of the PV system is greater than 5 lbs/ft², see WKS1.

Explanation: The 5 lbs/ft² limit is based on two things: 1) the roof is typical of standard code-compliant roof structures so that the structure either has the proper spans and spacing, or proper use of engineered trusses (first item under "Step 1: Structural Review"); and, 2) there is a single layer of roofing so that the normal weight allowance for additional roof layers is unused and available for the weight of the PV system. For applications on lightweight masonry roofing materials and other lightweight roofing products (e.g. metal, shake, etc...), these materials do not accept multiple layers and therefore the 5 lbs/ft² allowance is used to identify the maximum allowable additional weight for roofs that are exchanging the allowable live load for a dead load that prevents live load such as people walking on the roof.

Section 3. Step 2: Electrical Review of PV System (Calculations for Electrical Diagram)

In order for a PV system to be considered for an expedited permit process, the following must apply:

1. PV modules, utility-interactive inverters, and combiner boxes are identified for use in PV systems.

Explanation: PV utility-interactive inverters must be specifically listed and labeled for this application (as required by NEC 690.60 and 690.4) (Numbers in brackets refer to sections in the 2008 NEC throughout this document.). Without this specific identification process an unacceptable amount of review would be necessary to approve an inverter. Inverters that pass UL1741 and are listed as "utility-interactive" have met the requirement. Over 500 inverters currently meet this requirement. An inclusive list of these inverters is available online at

<http://gosolarcalifornia.com/equipment/inverter.php>.

PV modules must also be listed and identified for use in PV systems (as required by NEC 690.4). PV modules that pass UL1703 and have a 600-Volt maximum voltage meet the requirement. A list of these inverters is available online at <http://gosolarcalifornia.com/equipment/pvmodule.php>. Source-combiners must be listed and labeled to meet the dc voltage requirements of the PV system or be specifically tested for PV systems and clearly state the allowable maximum current and voltage (as required by NEC 690.4).

2. The PV array is composed of 4 series strings or less, and 15 kW_{STC} or less.

Explanation: The purpose of this requirement is to limit the number of options of what can comply as a “simple” system so that a single electrical diagram can be used to describe a large portion of the systems being installed. The electrical diagram can handle up to 4 strings in parallel. The maximum of 15 kW refers to the array size based on the total installed nameplate capacity. The limit is set to stay generally within electrical interconnections that would be considered simple and possibly able to meet the 120% of busbar rating allowance in NEC 690.64(B) in a residence (Minimum breaker for a 13.44 kW_{ac} PV system is 70 amps) .

3. The Inverter has a continuous power output 13,440 Watts or less

Explanation: A 70-amp breaker is important since a 225-amp busbar in a 200-amp panel will allow a 70-amp PV breaker. Since this does happen from time to time, and an installer can choose to install such a panelboard, it is considered the largest “simple” PV system for purposes of this guideline. A table of breaker/panelboard combinations is in Section 9 of this Guideline.

4. The ac interconnection point is on the load side of service disconnecting means (NEC 690.64(B)).

Explanation: Load side interconnections are by far the most common, particularly in residential applications. Any line side connection is covered by NEC 690.64(A) and 230.82. Although line side connections can be quite straightforward, they should require an additional step in the approval process and require a slightly different electrical drawing.

5. The electrical diagram (E1.1) can be used to accurately represent the PV system.

Explanation: The basis for a simplified permit is the use of the standard electrical diagram. Clearly, PV systems can vary significantly in PV array layout and inverter selection. However, the majority of small-scale, residential-sized PV systems can be accurately represented by this diagram. This diagram must be completely filled out in order for the permit package to be considered complete. This diagram is not intended for use with battery-based systems.

Section 4. Inverter Information

A copy of the manufacturer’s specification sheet is required for a permit submittal. In addition, a printed out digital photo of the inverter listing label can be very helpful for gathering the ratings of the equipment. A prerequisite for a code-approved installation is the use of a listed inverter [NEC 690.4; 690.60]. To determine if an inverter is listed by a Nationally Recognized Testing Laboratory (NRTL) to UL Std.1741, the listing label can be examined to see if it is labeled “Utility-Interactive.” If the utility-interactive labeling is not provided, does the unit comply with the requirements of IEEE Std. 1547 as verified the instruction manuals validated by the listing agency. For a current list of compliant inverters, visit the *Go Solar California* website at <http://gosolarcalifornia.com/equipment/inverter.php>. Some NRTLs have current listing information online as well.

- a) INVERTER MAKE: This is the manufacturer’s name: (e.g. PV Powered, SMA, etc...)
- b) INVERTER MODEL #: This is the model number on the listing label: (e.g. PVP 5200, SB7000US, etc...)

- c) MAX DC VOLTAGE RATING: Provided either on listing label or specification sheet.
- d) MAX POWER @ 40°C: The maximum continuous output power at 40°C is required information for the listing label and the Go Solar California website. If the specification sheet does not clearly state the value, consult either of these other two sources.
- e) NOMINAL AC VOLTAGE: This is the ac output voltage of the inverter as configured for this project. Some inverters can operate at multiple ac voltages.
- f) MAX OCPD RATING: This is the maximum overcurrent protective device (OCPD) rating allowed for the inverter. This is either stated on the listing label or in the installation manual. Sometimes this is also listed on the specification sheet—but not always. It is important to check that the inverter OCPD rating in the panel is less than or equal to this maximum rating to preserve the listing of the inverter.

Section 5. Module Information

A copy of the manufacturer's specification sheet is required for a permit submittal. In addition, a printed out digital photo of the module listing label can be very helpful for gathering the ratings of the equipment. A prerequisite for a code-approved installation is the use of a listed PV modules [NEC 690.4] to UL 1703. For a current list of modules that are listed to UL 1703, visit the *Go Solar California* website, <http://gosolarcalifornia.com/equipment/pvmodule.php>.

Explanation: This module information is particularly important since it is used to calculate several current and voltage parameters required by the National Electrical Code (NEC). Listing information is necessary for NEC testing requirements [90.7, 100, 110.3, 690.4]. (Numbers in brackets refer to sections in the 2008 NEC throughout this document.)

- a) MODULE MANUFACTURER: This is the manufacturer's name: (e.g. Evergreen, SunPower, etc...)
- b) MODULE MODEL #: This is the model number on the listing label: (e.g. EGS185, SP225, etc...)
- c) MAXIMUM POWER-POINT CURRENT (I_{MP})

Explanation: The rated I_{MP} is needed to calculate system operating current. This is the current of the module when operating at STC and maximum power.
- d) MAXIMUM POWER-POINT VOLTAGE (V_{MP})

Explanation: The rated V_{MP} is needed to calculate system operating voltage. This is the voltage of the module when operating at STC and maximum power.
- e) OPEN-CIRCUIT VOLTAGE (V_{OC})

Explanation: The rated V_{OC} is needed to calculated maximum system voltage specified in NEC 690.7.
- f) SHORT-CIRCUIT CURRENT (I_{SC})

Explanation: The rated I_{SC} is needed to calculate maximum current specified in NEC 690.8(A).
- g) MAXIMUM SERIES FUSE (OCPD)

Explanation: Maximum series fuse (OCPD) rating is needed to ensure that the proper overcurrent protection is provided for the modules and array wiring.
- h) MAXIMUM POWER (P_{MAX}) at Standard Test Conditions (STC is 1000W/m², 25°C cell temp, & Air Mass 1.5)

Explanation: Maximum power at STC specifies the rated power of the PV module under simulated conditions.

i) MAXIMUM SYSTEM VOLTAGE

Explanation: Maximum system voltage (often 600 V_{ac}) is needed to show that the NEC 690.7 voltage does not exceed this value.

Section 6. Array information

This section defines the configuration of the PV array. PV arrays are generally made up of several modules in series, called source-circuits. These source-circuits are often paralleled with multiple other source-circuits to make up the entire dc generating unit called the array. The last four items related to the PV array must be calculated and posted on a sign at the PV Power Source disconnect. The first two items a) and b) characterize the array design and provides the information necessary to calculate the four items needed to produce proper array identification for PV Power Source sign discussed in Section 7 that is required at the site.

a) NUMBER OF MODULES IN SERIES

Explanation: For simplicity, this diagram only addresses the most common configuration of PV modules—multiple modules in series. Although single module PV power sources exist, it is more common to see PV arrays configured with as many as 12 or 16 modules in series.

b) NUMBER OF PARALLEL CIRCUITS

Explanation: Since single-phase inverters can be as large as 12 kW or more, and the largest PV source circuits are only 2 or 3 kW, it is common for PV arrays to have two or more source circuits in parallel. From Example in Appendix One:

*Number of modules in series = 12
Number of parallel source circuits = 4
Total number of modules = 12 x 4 = 48*

c) LOWEST EXPECTED AMBIENT TEMP

Explanation: Up through the 2008 edition, the NEC has not clearly defined “lowest expected ambient temperature.” ASHRAE (American Society of Heating, Refrigeration, and Air Conditioning Engineers) has performed statistical analysis on weather data from the National Weather Service. These data include values for the mean extreme temperatures for the locations with temperature data. The mean extreme low temperature is the coldest expected temperature for a location. Half of the years on record have not exceeded this number, and the rest have exceeded this number. These data are supplied in the appendix for reference. A proposal is likely to be accepted for the 2011 NEC to include a Fine Print Note to 690.7 that specifies the use of the ASHRAE mean extreme value for lowest expected ambient temperature.

d) HIGHEST CONTINUOUS TEMP (ambient)

Explanation: Up through the 2008 edition, the NEC has not clearly defined “highest continuous ambient temperature.” Continuous is defined in the NEC as a 3-hour period (Article 100). ASHRAE (American Society of Heating, Refrigeration, and Air Conditioning Engineers) has performed statistical analysis on weather data from the National Weather Service. These data include design values of 0.4%, 1%, and 2% for each month signifying that the temperature only exceeds the recorded value up to 2% of the time for a given location with temperature data. The 2% value has been chosen by the Copper Development Institute as the value that best represents a condition that would create the 3-hour continuous condition referred to in Article 100. Two percent of one month is about 14 hours. Since high

temperatures usually last for several days in most locations, the assumption is that at least one or two 3-hour high temperature events will happen during a given month. These data are supplied in the appendix for reference. A proposal for the 2011 NEC has been submitted to include a Fine Print Note to Table 310.16 that specifies the use of the ASHRAE 2% data for the hottest month to determine highest continuous ambient temperature.

Section 7. SIGNS

a) PV POWER SOURCE

i) RATED MPP (MAXIMUM POWER-POINT) CURRENT (sum of parallel source circuit operating currents)

Explanation: Rated MPP current is found by multiplying the module rated MPP current for a module series string by the number of source circuits in parallel.

From the example in Appendix One:

$$I_{MP} = 4.89 \text{ amps}$$

$$\text{Number of source circuits in parallel} = 4$$

$$4.89 \text{ amps} \times 4 = 19.6 \text{ amps}$$

ii) RATED MPP (MAXIMUM POWER-POINT) VOLTAGE (sum of series modules operating voltage in source circuit)

Explanation: Operating voltage is found by multiplying the module rated MPP voltage by the number of modules in a series source circuit.

From the example in Appendix One:

$$V_{MP} = 35.8 \text{ Volts}$$

$$\text{Number of modules in series} = 12$$

$$35.8 \text{ Volts} \times 12 = 430 \text{ Volts}$$

iii) MAXIMUM SYSTEM VOLTAGE [NEC 690.7]

Explanation: Maximum system voltage is calculated by multiplying the value of V_{oc} on the listing label by the appropriate value on Table 690.7 in the NEC, and then multiplying that value by the number of modules in a series string. The table in the NEC is based on crystalline silicon modules and uses lowest expected ambient temperature at a site to derive the correction factor. Some modules do not have the same temperature characteristics as crystalline silicon so the manufacturer's instructions must be consulted to determine the proper way to correct voltage based on lowest expected ambient temperature.

From the example in Appendix One:

$$\text{Module } V_{oc} = 44.4 \text{ Volts}$$

$$\text{Number of Modules in Series} = 12$$

$$\text{Lowest expected ambient temperature (ASHRAE)} = 0^\circ\text{C (San Jose, California)}$$

Method 1—NEC Table 690.7:

$$\text{Maximum System Voltage} = V_{MAX} = V_{oc} \times \text{No. of Modules in Series} \times \text{Table 690.7 Value}$$

$$V_{MAX} = 44.4\text{V} \times 12 \times 1.10 = 586 \text{ Volts} < 600\text{Volts (sized properly)}$$

Method 2—Manufacturer's Temperature Correction Data:

$$\text{Temperature Coefficient for } V_{oc} = \alpha V_{oc} = -0.33\%/^\circ\text{C} = -0.0033/^\circ\text{C}$$

$$\text{Rated Temperature} = 25^\circ\text{C}$$

$$\text{Temperature Increase per Module:}$$

Percentage Method:

$$V_{MODMAX} = V_{OC} + V_{OC} \times \alpha \times V_{OC} (\%) \times (Temp_{LOW} - Temp_{RATED})$$

Voltage Method:

$$V_{MODMAX} = V_{OC} + \alpha \times V_{OC} (V) \times (Temp_{LOW} - Temp_{RATED})$$

Maximum System Voltage = $V_{MAX} = V_{MODMAX} \times \text{Number of Modules in Series}$

Maximum System Voltage = $V_{MAX} = 44.4V + 44.4V \times -0.0033/^\circ C \times (0^\circ C - 25^\circ C) \times 12$

$V_{MAX} = [44.4V + 44.4V \times -0.0033/^\circ C \times (-25^\circ C)] \times 12 = 577 \text{ Volts} < 600\text{Volts (sized properly)}$

iv) MAXIMUM CIRCUIT CURRENT [NEC 690.8]

Explanation: The maximum circuit current is calculated by multiplying the rated I_{sc} of the PV module by the number of source circuits operating in parallel, then multiplying this value by 125% to account for extended periods of sunlight above the tested solar intensity (rated irradiance= 1000 W/m^2 ; maximum continuous irradiance= 1250 W/m^2). The NEC in 690.53 asks for the short-circuit current in the 2005 and 2008 editions, but the 2008 edition clarifies in a Fine Print Note that the intended value is the maximum circuit current as defined in 690.8 (A) and is a worst-case continuous short-circuit current value.

From the example in Appendix One:

$$I_{SC} = 5.30 \text{ amps}$$

$$\text{Number of source circuits in parallel} = 4$$

$$5.30 \text{ amps} \times 4 \times 1.25 = 26.5 \text{ amps}$$

b) WARNING SIGN REQUIRED BY NEC 690.17.

Explanation: Any time a switch can have the load side energized in the open position, a warning sign must be placed on the switch. This is nearly always true of the dc disconnect at the inverter. The line side of the switch is energized by the PV array, while the load side of the switch is often energized by input capacitors of the inverter. These capacitors can remain energized for five minutes or more as the bleed resistors dissipate the charge over time. The warning sign should read essentially:

WARNING: ELECTRICAL SHOCK HAZARD—LINE AND LOAD MAY BE ENERGIZED IN OPEN POSITION

c) Point of Connection Sign [NEC 690.54]

(To be placed on the Solar AC Disconnect and AC Point of Connection locations)

i) AC OUTPUT CURRENT

Explanation: The ac output current, or rated ac output current as stated in the NEC, at the point of connection is the maximum current of the inverter output at full power. When the rated current is not specifically called out in the specification sheets, it can be calculated by taking the maximum power of the inverter, at $40^\circ C$, and dividing that value by the nominal voltage of the inverter.

From the example in Appendix One:

$$\text{Maximum Inverter Power} = 7,000 \text{ watts}$$

$$\text{Nominal Voltage} = 240 \text{ Volts}$$

$$I_{RATED} = 7,000 \text{ W} / 240 \text{ V} = 29.2 \text{ amps}$$

ii) NOMINAL AC VOLTAGE

Explanation: The nominal ac voltage, or nominal operating ac voltage as stated in the NEC, at the point of connection is the nominal voltage (not maximum or minimum) of the inverter output. It will be the same as the service voltage. Most residential inverters operate at 240 Volts.

From the example in Appendix One:

$$\text{Nominal Voltage} = 240 \text{ Volts}$$

Section 8. Wiring and Overcurrent Protection

a) DC Wiring Systems:

Source-circuit conductors:

In Exposed Locations:

PV module interconnections are generally 90°C wet-rated conductors (NEC 690.31(A) FPN). The same conductor type is typically used for all home run conductors needed for source circuit conductors in exposed locations.

Allowable wire types are as follows:

- USE-2 single conductor cable for exposed locations. [NEC 690.31(B)]
- PV Wire or PV Cable as a single conductor for exposed locations (required for all ungrounded systems). [NEC 690.31(B)]

Explanation for the need for High Temperature Conductors: Typical temperature for PV modules in full sun at 20°C outdoor temperature is 50°C. This is a 30°C rise above outdoor temperatures. On the hottest day of the year, outdoor temperatures can reach a continuous temperature of 41°C in many hot locations throughout the United States. This means that the PV module could be operating at 71°C on the hottest day of the year (41°C+30°C=71°C). 75°C wire is insufficient for connection to a hot PV module under this condition.

To further support the concern over the high temperature of PV modules, a fine print note has been added to the 2005 NEC.

NEC 690.31 (A) FPN: Photovoltaic modules operate at elevated temperatures when exposed to high ambient temperatures and to bright sunlight. These temperatures may routinely exceed 70°C (158°F) in many locations. Module interconnection conductors are available with insulation rated for wet locations and a temperature rating of 90°C (194°F) or greater.

In Conduit on Rooftops:

TWO OPTIONS FOR SOURCE CIRCUIT CONDUCTOR TYPE (INSIDE CONDUIT—CIRCLE ONE) THWN-2 and XHHW-2

Explanation: Conductors in conduit, when exposed to direct sunlight, must account for the higher temperatures caused by intense sunlight and the proximity of the roof. The 2005 NEC first recognized the issue of sunlit conduit in a fine print note in NEC 310.10.

“310.10 FPN No. 2: Conductors installed in conduit exposed to direct sunlight in close proximity to rooftops have been shown, under certain conditions, to experience a temperature rise of 17°C (30°F) above ambient temperature on which the ampacity is based.”

The 2008 NEC codified this issue by classifying the temperatures based on the height above the roof surface. On residential roofs, where conduit typically is spaced between ½” and 3 ½” above the roof surface, the temperature adder is stated as 22°C above the ambient temperature according to NEC Table 310.15(B)(2)(c). Using this adder, along with the

ASHRAE 2% design data for the hottest location in the U.S. (Palm Springs, CA is 44°C), produces a design temperature of 66°C and correction factor of 0.58 for 90°C conductors based on NEC Table 690.31 and Table 310.16. If nine conductors or less are in the exposed conduit (4 pairs of conductors or less), then the conduit fill correction factor is 0.7 according to NEC Table 310.15(B)(2)(a). Putting all these correction factors together means that the 30°C conductor ampacity must be as follows:

If only two strings in parallel (no fuses):

$$I_{30^{\circ}\text{C}} = I_{\text{MAX}}/0.58/0.7 = 2.46 \times I_{\text{MAX}}$$

If $I_{\text{SC}} = 9.6$ amps or less, then $I_{\text{MAX}} = I_{\text{SC}} \times 1.25 = 12$ amps or less.

If $I_{\text{MAX}} = 12$ Amps, then $I_{30^{\circ}\text{C}} = 29.5$ Amps (12 AWG, 90°C required (NEC Table 310.16))

If $I_{\text{SC}} = 6.4$ amps or less, then $I_{\text{MAX}} = I_{\text{SC}} \times 1.25 = 8$ amps or less.

If $I_{\text{MAX}} = 8$ Amps, then $I_{30^{\circ}\text{C}} = 19.7$ Amps (14 AWG, 90°C required (NEC Table 310.16))

If fuses are needed to protect PV modules (most cases):

$$I_{30^{\circ}\text{C}} = I_{\text{FUSE}}/0.58/0.7 = 2.46 \times I_{\text{FUSE}}$$

If $I_{\text{SC}} = 9.6$ amps or less, then $I_{\text{MAX}} = I_{\text{SC}} \times 1.25 = 12$ amps. The minimum overcurrent protective device (OCPD) as required by 690.8(B) is 15 amps ($I_{\text{FUSE}} = I_{\text{MAX}} \times 1.25 = 15\text{A}$).

If $I_{\text{FUSE}} = 15$ Amps, then $I_{30^{\circ}\text{C}} = 2.46 \times 15\text{A} = 36.9$ Amps (10 AWG, 90°C required (NEC Table 310.16)—15A fuse to protect the conductor)

If $I_{\text{SC}} = 7.68$ amps or less, then $I_{\text{MAX}} = I_{\text{SC}} \times 1.25 = 9.6$ amps. The minimum overcurrent protective device (OCPD) as required by NEC 690.8(B) is 12 amps ($I_{\text{FUSE}} = I_{\text{MAX}} \times 1.25 = 12\text{A}$).

If $I_{\text{FUSE}} = 12$ Amps, then $I_{30^{\circ}\text{C}} = 2.46 \times 12\text{A} = 29.5$ Amps (12 AWG, 90°C required (NEC Table 310.16)—12A fuse to protect the conductor)

If $I_{\text{SC}} = 6.4$ amps or less, then $I_{\text{MAX}} = I_{\text{SC}} \times 1.25 = 8$ amps. The minimum overcurrent protective device (OCPD) as required by 690.8(B) is 10 amps ($I_{\text{FUSE}} = I_{\text{MAX}} \times 1.25 = 10\text{A}$).

If $I_{\text{FUSE}} = 10$ Amps, then $I_{30^{\circ}\text{C}} = 2.46 \times 10\text{A} = 24.6$ Amps (14 AWG, 90°C required (NEC Table 310.16)—10A fuse to protect the conductor)

Maximum Module I_{SC}	Required Fuse Size	Minimum Conductor Size in Conduit (9 conductors)	Minimum Conductor Size in Free Air (at modules)
9.6 Amps	15 Amps	10 AWG	10 AWG
7.68 Amps	12 Amps	12 AWG	12 AWG
6.4 Amps	10 Amps	14 AWG	14 AWG

Since the highest I_{SC} module commonly available as of the writing of this guide is less than 9 amps, 10 AWG conductors will always work regardless of location in the U.S. as long as there

are no more than 9 current carrying conductors in the conduit and the conduit is at least 0.5" above the roof surface. Smaller wire can be used according to the I_{SC} of the modules being used and the number of conductors in the conduit. These calculations are provided so that contractors and jurisdictions will not need to repeat these standard calculations over and over. A simple table summarizes the minimum conductor sizes.

b) AC Wiring Systems

Inverter Output Circuit overcurrent protection should be sized and protected according the manufacturer's directions. The circuit and corresponding overcurrent protection should be sized at a 125% of the maximum continuous output of the inverter [NEC 215.3 Overcurrent for Feeder Circuits, and NEC 690.8(A)(3) and 690.8(B)]. The 125 percent increase over the maximum Inverter Output Circuit current is to account for the standard listing of overcurrent devices to 80% of maximum circuit current for continuous duty. The inverter may also have a maximum allowable overcurrent requirement.

Explanation: *For instance, the SMA SB7000US has a maximum continuous output of 29.2 amps and a maximum allowable overcurrent protection of 50 amps. This means that the minimum allowable overcurrent is 40 amps (29.2 amps x 1.25 = 36.5 amps—round up to the next standard size, which is 40 amps) and a maximum of 50 amps. Normally the minimum allowable breaker size is used since the panelboard supply breakers are constrained to 120% of the panelboard busbar rating.*

From the example in Appendix One:

Inverter continuous output rating = 7000 Watts

Nominal inverter voltage = 240 Volts

Maximum operating current = 7000 Watts / 240 Volts = 29.2 Amps

Min. Inverter Output Circuit ampacity = 29.2 Amps x 1.25 = 36.5 Amps

Section 9. AC Point of Connection

NEC 690.64 (B) covers the requirements for Point of Connection of the PV inverter to the building electrical system. The most common method of connection is through a dedicated circuit breaker to a panelboard busbar. The sum of the supply breakers feeding the busbar of a panel can be up to 120% of the busbar rating. Appendix B treats this subject in detail.

Explanation: *A service panel containing a 200-amp busbar and a 200-amp main breaker will allow breakers totaling 120% of the busbar rating (240-amps). Since the main breaker is 200 amps, the PV breaker can be up to 40 amps without exceeding the 120% allowance. For a service panel with a 125-amp busbar and a 100-amp main breaker, this provision will allow up to a 50 amp breaker (125 amps x 1.2 = 150 amps; 150 amps – 100 amp main breaker = 50 amp PV breaker).*

A provision in the 2005 NEC clarifies the fact that dedicated circuit breakers backfed from listed utility-interactive inverters do not need to be individually clamped to the panelboard busbars. This has always been the case, but many inspectors have employed the provisions of NEC 408.36(F) that the breaker be secured in place by an additional fastener. Utility-interactive inverters do not require this fastener since they are designed to shut down immediately should the dedicated breaker become disconnected from the bus bar under any condition. This provision is repeated in the 2008 NEC in a clear and concise statement:

NEC 690.64(B)(6) Fastening. Listed plug-in-type circuit breakers backfed from utility-interactive inverters complying with 690.60 shall be permitted to omit the additional fastener normally required by 408.36(D) for such applications.

NEC 690.64 (B) covers the requirements for Point of Connection of the PV inverter to the building electrical system, which is the most common method of connection. The table below shows the how the maximum current of the inverter (column 1) requires a minimum size OCPD (column 2), which requires a minimum size conductor (column 3), which requires a compatible busbar/main breaker combination in the panelboard (column 4). The way to understand column 4, minimum busbar/main breaker combinations is to look at the row that coincides with the particular breaker being selected (from column 2) and use any combination from column 4 found on that row or higher in the table. For instance, a 40-Amps inverter breaker works with a 200/200 panel combination, but it also works with a 125/100 combination found on the row above. The 40-Amp breaker does not work on the 150/150 combination, since the largest breaker would be 30 amps for the 150/150 combination.

Table of NEC 690.64(B) AC Interconnection Options

Maximum Inverter Current	Required Inverter OCPD Size	Minimum Conductor Size in Conduit	Minimum Busbar/Main Breaker Combinations (Busbar Amps/Main Amps)
64 Amps	80 Amps	4 AWG	400/400; 200/150
56 Amps	70 Amps	4 AWG	225/200; 250/225
48 Amps	60 Amps	6 AWG	300/300; 200/175
40 Amps	50 Amps	8 AWG	125/100; 150/125
32 Amps	40 Amps	8 AWG	225/225; 200/200; 150/125
24 Amps	30 Amps	10 AWG	150/150
16 Amps	20 Amps	12 AWG	100/100; 70/60
12 Amps	15 Amps	14 AWG	80/80

Section 10. Grounding

a) System Grounding

The NEC requires [690.41] that all systems operating above 50 volts have one conductor referenced to ground unless the system complies with the requirements of NEC 690.35 for ungrounded PV arrays.

b) Equipment Grounding

The code also requires that all exposed non-current-carrying metal parts of module frames, equipment, and conductor enclosures be grounded regardless of system voltage [NEC 690.43]. The grounding of module frames has received significant attention in the last several years. Many jurisdictions, with a heightened concern over the issue, have dramatically restricted effective grounding options. A discussion on module frame grounding is found in the Appendix.

c) Sizing of Grounding Conductors

i) Equipment grounding conductor (EGC) sizing [NEC 690.45]

The size of the EGC is dependent on whether the system has ground fault protection (GFP) equipment or not. The provisions for GFP equipment are stated in NEC 690.5.

Almost all inverters have GFP equipment integral to the inverter and require that the PV array be grounded at the inverter only.

(1) Systems with ground fault protection equipment

Size equipment grounding conductor according to NEC Table 250.122.

(2) Systems without ground fault protection equipment

The NEC requires that equipment grounding conductors for systems without GFP equipment be sized for twice the circuit short circuit current [NEC 690.45].

ii) System grounding conductor sizing

(1) AC System

Size grounding electrode conductor (GEC) according to NEC Table 250.66.

Normally the site already has the conductor and electrode installed for the ac building wiring.

(2) DC System

Size grounding electrode conductor (GEC) according to NEC 250.166. This results in a minimum size of 8 AWG. The maximum size of the GEC is dependent upon the type of grounding electrode or the maximum size conductor in the system, whichever is smaller.

APPENDIX

APPENDIX A: EXAMPLE SUBMITTAL

Step 1: Structural Review of PV Array Mounting System

Is the array to be mounted on a defined, permitted roof structure? Yes No

(structure meets modern codes)

If No due to non-compliant roof or ground mount, submit completed worksheet for roof structure WKS1.

Roof Information:

1. Is the roofing type lightweight (Yes = composition, lightweight masonry, metal, etc...) Yes—composition
If No, submit completed worksheet for roof structure WKS1 (No = heavy masonry, slate, etc...).
2. Does the roof have a single roof covering? Yes No
If No, submit completed worksheet for roof structure WKS1.
3. Provide method and type of weatherproofing roof penetrations (e.g. flashing, caulk). flashing

Mounting System Information:

1. The mounting structure is an engineered product designed to mount PV modules? Yes No
If No, provide details of structural attachment certified by a design professional.
2. For manufactured mounting systems, fill out information on the mounting system below:
 - a. Mounting System Manufacturer UniRac Product Name and Model# SolarMount
 - b. Total Weight of PV Modules and Rails 1780 lbs
 - c. Total Number of Attachment Points 48
 - d. Weight per Attachment Point (b÷c) 37 lbs (if greater than 40 lbs, see WKS1)
 - e. Maximum Spacing Between Attachment Points on a Rail 48 inches (see product manual for maximum spacing allowed based on maximum design wind speed)
 - f. Total Surface Area of PV Modules (square feet) 674 ft²
 - g. Distributed Weight of PV Module on Roof (b÷f) 2.64 lbs/ft²

If distributed weight of the PV system is greater than 5 lbs/ft², see WKS1.

Step 2: Electrical Review of PV System (Calculations for Electrical Diagram)

In order for a PV system to be considered for an expedited permit process, the following must apply:

1. PV modules, utility-interactive inverters, and combiner boxes are identified for use in PV systems.
2. The PV array is composed of 4 series strings or less, and 15 kW_{STC} or less.
3. The Inverter has a continuous power output 13,440 Watts or less
4. The ac interconnection point is on the load side of service disconnecting means (690.64(B)).
5. The electrical diagram (E1.1) can be used to accurately represent the PV system.

Fill out the standard electrical diagram completely. A guide to the electrical diagram is provided to help the applicant understand each blank to fill in. If the electrical system is more complex than the standard electrical diagram can effectively communicate, provide an alternative diagram with appropriate detail.

EQUIPMENT SCHEDULE

TAG	DESCRIPTION	PART NUMBER	NOTES
1	SOLAR PV MODULE	SW 175 mono	SOLAR WORLD, QUANTITY - 36 (SEE NOTES SHEET FOR DETAILS)
2	PV ARRAY	N/A	ARRAY IS 4 STRINGS WITH 12 MODULES PER SERIES STRING
3	J-BOX (IF USED)	NEMA 4, PVC JUNCTION BOX	
4	COMBINER (IF USED)	SMA-supplied	15-A MAX FUSE W/1/5-A FUSES, 600VDC, 4-STRING MAX
5	DC DISCONNECT	SMA-supplied	LISTED WITH INVERTER, 600VDC, 60-AMP (SEE GUIDE APPENDIX B)
6	DC/AC INVERTER	SB7000US	GENERAL ELECTRIC (SEE NOTES SHEET FOR DETAILS)
7	GEN METER (IF USED)	FORM 2S	GENERAL ELECTRIC 4-JAW
8	AC DISCONNECT (IF USED)	D222NRB	SQUARE D, 240VAC, 60-AMP FUSED (SEE GUIDE APPENDIX B)
9	SERVICE PANEL	SD200SL	240VAC, 200-A MAIN, 200-A BUS, 40-A INVERTER OCPD (SEE NOTE 5 FOR INVERTER OCPDs, ALSO SEE GUIDE SECTION 9)

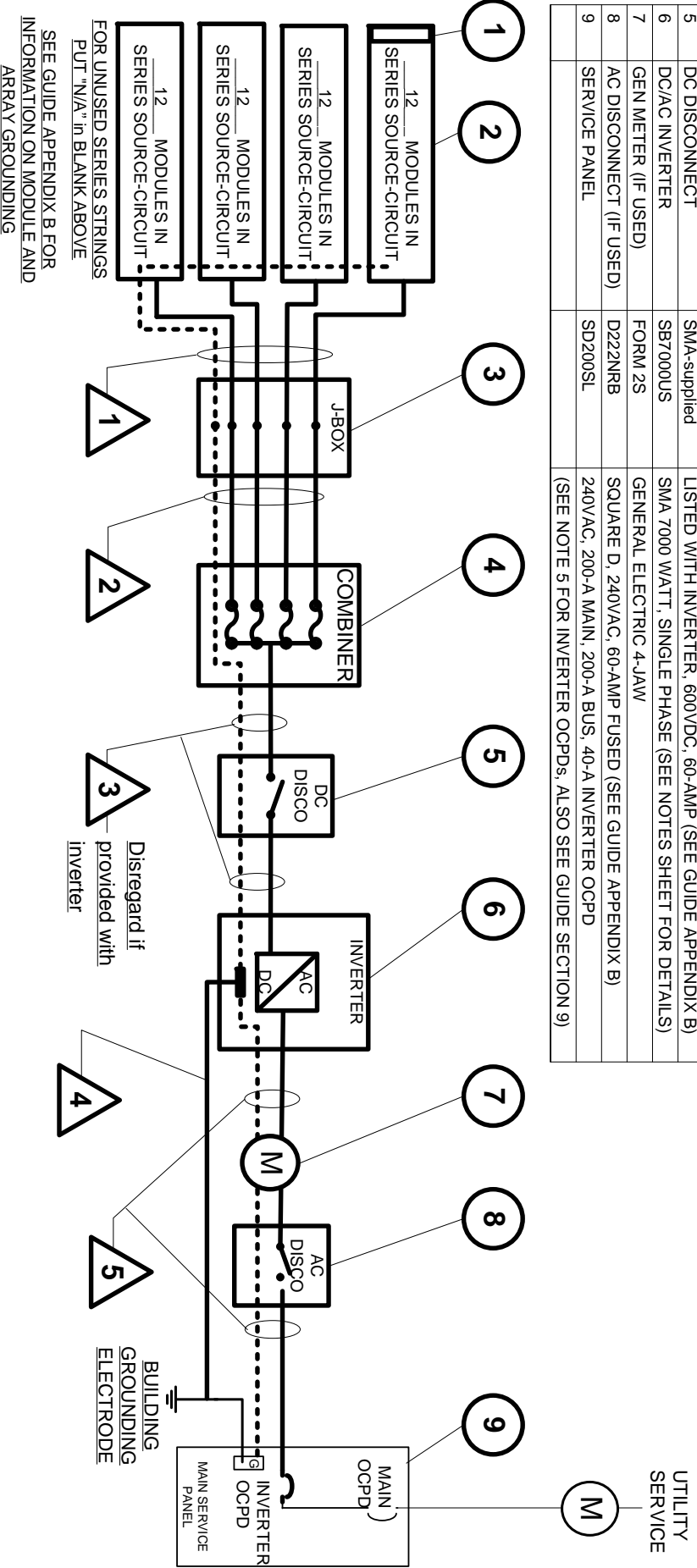

CONDUIT AND CONDUCTOR SCHEDULE

TAG	DESCRIPTION OR CONDUCTOR TYPE	COND.	NUMBER OF CONDUCTORS	CONDUIT TYPE	CONDUIT SIZE
1	USE-2 <input checked="" type="checkbox"/> or PV WIRE <input type="checkbox"/>	10 AWG	8 BLACK	N/A	N/A
2	BARE COPPER EQ. GRD. COND. (EGC)	10 AWG	1 BARE CU	N/A	N/A
3	THWN-2 <input checked="" type="checkbox"/> or XHHW-2 <input type="checkbox"/> or RHW-2 <input type="checkbox"/>	10 AWG	4-R, 4-W, 1-G	EMT	3/4"
4	INSULATED EGC	N/A	N/A	N/A	N/A
5	DC GROUNDING ELECTRODE COND.	6 AWG	1 BARE CU	N/A	N/A
6	THWN-2 <input checked="" type="checkbox"/> or XHHW-2 <input type="checkbox"/> or RHW-2 <input type="checkbox"/>	8 AWG	1-R, 1-B, 1-W	EMT	3/4"
7	INSULATED EGC	10 AWG	1 GREEN		

One-Line Standard Electrical Diagram for Small-Scale, Single-Phase PV Systems

Contractor Name:
Address and Phone:
Bill and Ted's Solar
456 Industrial Drive
San Jose, CA
408-555-1212

Site Name: Joe and Jane Homeowner
Site Address: 123 Sunnyside St., San Jose, CA
System AC Size: 6.9 kW Solar Array

Drawn By: Bill
Checked By: Ted

SCALE: NTS
Date: _____
SHEET: _____

REV: 0

PV MODULE RATINGS @ STC (Guide Section 5)

MODULE MAKE	SOLAR WORLD
MODULE MODEL	SW 175
MAX POWER-POINT CURRENT (I_{MPP})	4.89 A
MAX POWER-POINT VOLTAGE (V_{MPP})	35.8 V
OPEN-CIRCUIT VOLTAGE (V_{OC})	44.4 V
SHORT-CIRCUIT CURRENT (I_{SC})	5.3 A
MAX SERIES FUSE (OCPD)	15 A
MAXIMUM POWER (P_{MAX})	175 W
MAX VOLTAGE (TYP 600V _{DC})	600 V
VOC TEMP COEFF (mV/°C <input type="checkbox"/> or %/°C <input checked="" type="checkbox"/>)	-0.33
IF COEFF SUPPLIED, CIRCLE UNITS	

NOTES FOR ALL DRAWINGS:

OCPD = OVERCURRENT PROTECTION DEVICE
 NATIONAL ELECTRICAL CODE® REFERENCES
 SHOWN AS (NEC XXX.XX)

INVERTER RATINGS (Guide Section 4)

INVERTER MAKE	SMA
INVERTER MODEL	SB7000US
MAX DC VOLT RATING	600 V
MAX POWER @ 40°C	7000 W
NOMINAL AC VOLTAGE	240 V
MAX AC CURRENT	29 A
MAX OCPD RATING	50 A

SIGNS-SEE GUIDE SECTION 7

SIGN FOR DC DISCONNECT

PHOTOVOLTAIC POWER SOURCE	
RATED MPP CURRENT	19.6 A
RATED MPP VOLTAGE	430 V
MAX SYSTEM VOLTAGE	577 V
MAX CIRCUIT CURRENT	26.5 A
WARNING: ELECTRICAL SHOCK HAZARD-LINE AND LOAD MAY BE ENERGIZED IN OPEN POSITION	

SIGN FOR INVERTER OCPD AND
 AC DISCONNECT (IF USED)

SOLAR PV SYSTEM	
AC POINT OF CONNECTION	
AC OUTPUT CURRENT	29 A
NOMINAL AC VOLTAGE	240 V
THIS PANEL FED BY MULTIPLE SOURCES (UTILITY AND SOLAR)	

NOTES FOR ARRAY CIRCUIT WIRING (Guide Section 6 and 8 and Appendix D):

- 1.) LOWEST EXPECT AMBIENT TEMPERATURE BASED ON ASHRAE MINIMUM MEAN EXTREME DRY BULB TEMPERATURE FOR ASHRAE LOCATION MOST SIMILAR TO INSTALLATION LOCATION. LOWEST EXPECTED AMBIENT TEMP ___ 0 °C
- 2.) HIGHEST CONTINUOUS AMBIENT TEMPERATURE BASED ON ASHRAE HIGHEST MONTH 2% DRY BULB TEMPERATURE FOR ASHRAE LOCATION MOST SIMILAR TO INSTALLATION LOCATION. HIGHEST CONTINUOUS TEMPERATURE ___ 34 °C
- 2.) 2005 ASHRAE FUNDAMENTALS 2% DESIGN TEMPERATURES DO NOT EXCEED 47°C IN THE UNITED STATES (PALM SPRINGS, CALS 44.1°C). FOR LESS THAN 9 CURRENT-CARRYING CONDUCTORS IN ROOF-MOUNTED SUNLIT CONDUIT AT LEAST 0.5" ABOVE ROOF AND USING THE OUTDOOR DESIGN TEMPERATURE OF 47°C OR LESS (ALL OF UNITED STATES),
 - a) 12 AWG, 90°C CONDUCTORS ARE GENERALLY ACCEPTABLE FOR MODULES WITH I_{SC} OF 7.68 AMPS OR LESS WHEN PROTECTED BY A 12-AMP OR SMALLER FUSE.
 - b) 10 AWG, 90°C CONDUCTORS ARE GENERALLY ACCEPTABLE FOR MODULES WITH I_{SC} OF 9.6 AMPS OR LESS WHEN PROTECTED BY A 15-AMP OR SMALLER FUSE.

NOTES FOR INVERTER CIRCUITS (Guide Section 8 and 9):

- 1) IF UTILITY REQUIRES A VISIBLE-BREAK SWITCH, DOES THIS SWITCH MEET THE REQUIREMENT? YES NO N/A
- 2) IF GENERATION METER REQUIRED, DOES THIS METER SOCKET MEET THE REQUIREMENT? YES NO N/A
- 3) SIZE PHOTOVOLTAIC POWER SOURCE (DC) CONDUCTORS BASED ON MAX CURRENT ON NEC 690.53 SIGN OR OCPD RATING AT DISCONNECT
- 4) SIZE INVERTER OUTPUT CIRCUIT (AC) CONDUCTORS ACCORDING TO INVERTER OCPD AMPERE RATING. (See Guide Section 9)
- 5) TOTAL OF ___ 1 ___ INVERTER OCPD(S). ONE FOR EACH INVERTER. DOES TOTAL SUPPLY BREAKERS COMPLY WITH 120% BUSBAR EXCEPTION IN 690.64(B)(2)(a)? YES NO

Notes for One-Line Standard Electrical
 Diagram for Single-Phase PV Systems

Site Name: Joe and Jane Homeowner
 Site Address: 123 Sunnyside St., San Jose, CA
 System AC Size: 6.9 kW Solar Array

Contractor Name, Address and Phone:		Bill and Ted's Solar 456 Industrial Drive San Jose, CA 408-555-1212	
Drawn By:	Bill	Checked By:	Ted
SIZE	FSCM NO	DWG NO	REV
SCALE	NTS	Date:	E1.2 0
SHEET		SHEET	

APPENDIX B: STRUCTURAL

STRUCTURE WORKSHEET WKS1

If array is roof mounted:

This section is for evaluating roof structural members that are site built. This includes rafter systems and site built trusses. Manufactured truss and roof joist systems, when installed with proper spacing, meet the roof structure requirements covered in item 2 below.

1. Roof construction: **Rafters** **Trusses** **Other:**

2. Describe site-built rafter or or site-built truss system.
 - a. Rafter Size: ___ x ___ inches
 - b. Rafter Spacing: _____ inches
 - c. Maximum unsupported span: _____ feet, _____ inches
 - d. Are the rafters over-spanned? (see the IRC span tables in **B.2.**) **Yes** **No**
 - e. If **Yes**, complete the rest of this section.
3. If the roof system has:
 - a. over-spanned rafters or trusses,
 - b. the array over 5 lbs/ft² on any roof construction, or
 - c. the attachments with a dead load exceeding 40 lbs per attachment;it is recommended that you provide one of the following:
 - i. A framing plan that shows details for how you will strengthen the rafters using the supplied span tables in B.2.
 - ii. Confirmation certified by a design professional that the roof structure will support the array.

If array is ground mounted:

1. Show array supports, framing members, and foundation posts and footings.
2. Provide information on mounting structure(s) construction. If the mounting structure is unfamiliar to the local jurisdiction and is more than six (6) feet above grade, it may require engineering calculations certified by a design professional.
3. Show detail on module attachment method to mounting structure.

B.2 SPAN TABLES

A framing plan is required *only* if the combined weight of the PV array exceeds 5 pounds per square foot (PSF or lbs/ft²) *or* the existing rafters are over-spanned. The following span tables from the 2003 International Residential Code (IRC) can be used to determine if the rafters are over-spanned. For installations in jurisdictions using different span tables, follow the local tables.

Span Table R802.5.1(1),

Use this table for rafter spans that have conventional light-weight dead loads and do *not* have a ceiling attached.

10 PSF Dead Load							
Roof live load = 20 psf, ceiling not attached to rafters, L/Δ=180							
Rafter Size			2 x 4	2 x 6	2 x 8	2 x 10	2 x 12
Spacing (inches)	Species	Grade	The measurements below are in feet-inches (e.g. 9-10 = 9 feet, 10 inches).				
16	Douglas Fir-larch	#2 or better	9-10	14-4	18-2	22-3	25-9
16	Hem-fir	#2 or better	9-2	14-2	17-11	21-11	25-5
24	Douglas Fir-larch	#2 or better	7-10	11-9	14-10	18-2	21-0
24	Hem-fir	#2 or better	7-3	11-5	14-8	17-10	20-9

Use this table for rafter spans that have heavy dead loads and do *not* have a ceiling attached.

20 PSF Dead Load							
Roof live load = 20 psf, ceiling not attached to rafters, L/Δ=180							
Rafter Size			2 x 4	2 x 6	2 x 8	2 x 10	2 x 12
Spacing (inches)	Species	Grade	The measurements below are in feet-inches (e.g. 9-10 = 9 feet, 10 inches).				
16	Douglas Fir-larch	#2 or better	8-6	12-5	15-9	19-3	22-4
16	Hem-fir	#2 or better	8-5	12-3	15-6	18-11	22-0
24	Douglas Fir-larch	#2 or better	6-11	10-2	12-10	15-8	18-3
24	Hem-fir	#2 or better	6-10	10-0	12-8	15-6	17-11

Span Table R802.5.1(2),

Use this table for rafter spans *with* a ceiling attached and conventional light-weight dead loads.

10 PSF Dead Load							
Roof live load = 20 psf, ceiling attached to rafters, L/Δ=240							
Rafter Size			2 x 4	2 x 6	2 x 8	2 x 10	2 x 12
Spacing (inches)	Species	Grade	The measurements below are in feet-inches (e.g. 9-10 = 9 feet, 10 inches).				
16	Douglas Fir-larch	#2 or better	8-11	14-1	18-2	22-3	25-9
16	Hem-fir	#2 or better	8-4	13-1	17-3	21-11	25-5
24	Douglas Fir-larch	#2 or better	7-10	11-9	14-10	18-2	21-0
24	Hem-fir	#2 or better	7-3	11-5	14-8	17-10	20-9

Use this table for rafter spans *with* a ceiling attached and where heavy dead loads exist.

20 PSF Dead Load							
Roof live load = 20 psf, ceiling attached to rafters, L/Δ=240							
Rafter Size			2 x 4	2 x 6	2 x 8	2 x 10	2 x 12
Spacing (inches)	Species	Grade	The measurements below are in feet-inches (e.g. 9-10 = 9 feet, 10 inches).				
16	Douglas Fir-larch	#2 or better	8-6	12-5	15-9	19-3	22-4
16	Hem-fir	#2 or better	8-4	12-3	15-6	18-11	22-0
24	Douglas Fir-larch	#2 or better	6-11	10-2	12-10	15-8	18-3
24	Hem-fir	#2 or better	6-10	10-0	12-8	15-6	17-11

Use the conventional light-weight dead load table when the existing roofing materials are wood shake, wood shingle, composition roofing or light-weight tile roofs. (The rationale for allowing these tables to be used is that the installation of a PV system should be considered as part of the live load, since additional loading will not be added to the section of the roof where a PV array is installed.)

Where heavy roofing systems exist (e.g. clay tile or heavy concrete tile roofs), use the 20 lbs/ft² dead load tables.

APPENDIX C: SPECIAL ELECTRICAL TOPICS

Module Frame Grounding:

The primary concern raised by industry experts, including the Solar ABCs, has been the fact that the anodized aluminum frames in contact with anodized aluminum rails may not create an adequate and reliable electrical connection. Until this issue was raised, most inspectors and contractors were satisfied with grounding the metal support structure rather than grounding individual modules. Several standard and new grounding methods can address the electrical bond of the module frame to its support by penetrating each nonconductive surface with a sharp, metallurgically compatible device. This device may be as simple as a stainless steel star washer, or as unique as a specially designed grounding clip with sharp points to pierce the anodizing.

PV module grounding options include a variety of methods including grounding screws or lugs on each module connected to a ground wire, or methods that create an electrical bond between the module frame and its support structure. Installation manuals for PV modules have become more explicit about grounding methods, but it is not necessary for the manual to state every possible method of compliance. The UL 1703 test standard for the safety of PV modules is being revised to allow any method that meets the requirements of UL 467, Grounding and Bonding Equipment as long as the metals are compatible and the materials are able to withstand an outdoor environment and expands the options for grounding modules.

AC Connection to Building Electrical Systems

AC Connection to Load Side of Main Service Panel

The connection of PV system's inverter output circuit to the load side of the Main Service panel is the most common installation method. This type of connection is governed by the requirements of *NEC* 690.64(B). These requirements dictate that the maximum sum of OCPDs that can be fed into a conductor or busbar is 120% of the busbar or conductor rating (*NEC* 690.64(B)(1)). For example, if a busbar has a current rating of 225-amps, and a main breaker rated at 200-amps, then the maximum breaker rating for a PV inverter is 70-amps as shown below:

Maximum allowable OCPD: Busbar = 225A; 120% of Busbar = $225A \times 1.2 = 270A$

Existing Main OCPD = 200A

Maximum PV OCPD = Maximum allowable OCPD – Existing Main OCPD
= $270A - 200A = 70A$

To determine the maximum size inverter that can be fed into a 70A OCPD, remember that most circuit breakers and other OCPDs are limited to 80% of their current rating for continuous operation. This means that 70A circuit breaker must be sized so that 56A can pass through the breaker on a continuous basis (3-hours or more). Since PV inverters are rated based on their maximum power at 40C for a continuous 3-hour period, an inverter capable of a continuous 56A is capable of 11,648 Watts at 208Vac; 13,440Wac at 240Vac; and 15,512Wac at 277Vac.

The only way to put more current into the load side of the service panel in this is example, is to reduce the size of the main OCPD. To the extent that the main OCPD is reduced, the PV inverter OCPD may be increased. However, any time a main OCPD is reduced, a load calculation following the requirements of *NEC* Article 220 must be calculated to show that the load on the main OCPD will not see more than an 80% continuous load at the chosen OCPD rating.

If no other panelboards exist on this service, the only other opportunity to install a larger PV system is to make a supply-side service connection (*NEC* 690.64(A)). This method is discussed in the *AC Supply Side Connection* section in this Appendix.

AC Connection to Subpanel:

When a site service contains more than one panelboard, the panels fed from the main service panel are referred to as subpanels. The *NEC*, in 690.64(B)(1), allows the inverter OCPD to be connected at any location in the premises wiring system, provided that the 120% of busbar and conductor ampacity limitation is observed.

For example, a large residence has a main panel with a 400-amp rating with a 400-amp main OCPD. From a 200-amp breaker in this 400-amp panel is a 200-amp panel at the opposite end of the residence. In this example, the PV array is located much closer to the 200-amp panel, so the preferred interconnection point is the 200-amp panel. As long as the inverter OCPD complies with limitations of the 200-amp panel, the inverter can interconnect at that panel.

With a 200-amp busbar and a 200-amp main breaker, the largest PV OCPD allowed in that panel is 40-amps (see discussion on *AC Connection to Load Side of Main Service Panel* in this Appendix). Assuming a 40-amp PV OCPD is sufficient for the PV inverter (e.g. 7000 Watt inverter), the issues of concern in the subpanel are addressed.

Now consider the current flow at the main service panel. The 2008 *NEC* instructs the installer to calculate the sum of the supply OCPDs at the main service panel based on the rating of inverter OCPD, which is 40-amps, not the 200-amp feeder breaker that feeds the subpanel [*NEC* 690.64(B)(1)]. Clearly, the 40-amp PV OCPD does not exceed the 120% of busbar rating in the 400-amp panel, whereas, had the 200-amp feeder breaker value been used in the calculation, the installation would have been in violation.

Taking this example one additional step, should another PV inverter be desired, due to the large electrical consumption of the residence, there is still ampacity allowance in the 400-amp main panel busbar. The allowable inverter OCPD size would be calculated as follows:

Maximum allowable OCPD: Busbar = 400A; 120% of Busbar = $400A \times 1.2 = 480A$

Existing Main OCPD = 400A; Inverter OCPD in 200A subpanel = 40A

Maximum PV OCPD in 400A panel = Maximum allowable OCPD – Existing Main OCPD
– Inverter OCPD in 200A subpanel = $480A - 400A = 40A$

Therefore an additional 40A inverter OCPD could be placed in the main panel without any changes to the panel.

Should a larger PV system be desired than could be handled by the two 40A breakers in this example, refer to the discussions in *AC Connection to Load Side of Main Service Panel* in this Appendix.

AC Supply Side Connection:

When the size of PV system is relatively large relative to the size of the site service, it is fairly common to consider a supply side connection for the inverter OCPD. Whenever the 120% allowance for OCPDs connected to busbars or conductors cannot be observed, due to size of the required PV OCPD and the limited size of the service panel, the supply side connection may be the only alternative available. A supply side connection by definition is made between the service meter and the service disconnect.

Not all services can be legally connected at this point. For instance, many all-in-one meter panels, used routinely in new residential construction, have no means of making such a connection without violating the listing of the product. On the other end of the size spectrum, many large 3,000-amp service panels have no space for such a connection. To further complicate this situation, some utilities have begun requiring metering current transformers to be installed on the load side of service OCPD, making a supply side connection impossible.

With those complications aside, we will discuss the situations where a supply side connection is possible and does not violate the equipment listings of the service equipment. The *NEC* covers supply side connections in 230.82. The supply side connection for the PV system must have a disconnect and OCPD located immediately adjacent to the main service disconnect as specified in 230.91. Even though the tap rule, discussed in Article 240.99 does not apply to supply side connections, the size of the conductors connecting the supply side connection to the PV OCPD are sized according to rating of the OCPD. Therefore, if a 60-amp fused disconnect is used as the PV OCPD, the conductor size between the supply side connection and the PV OCPD need only be 6AWG, regardless of the size of service conductors.

The method of termination of PV conductors to the supply conductors or busbar, depends on the service equipment and conductors. In any case, the service voltage will need to be interrupted to tie in to the service conductors or busbar unless the very rare exceptions outlined in NFPA 70E are involved at facilities like hospitals where the cut-in process must be done while energized. Typical termination methods include several options:

1. lugging to an accessible perforated bus within service equipment;
2. using empty set of double-barrel lugs within service equipment;
3. using piercing lugs on conductors between meter and service disconnect;
4. any lug identified for making connections to conductors of the size range installed.

Often installing lugs on service conductors will require removal of service conductors and conduit and reinstalling conductors with a junction box to accommodate the connection.

Source Circuit Overcurrent Protection:

Source circuit overcurrent protection must be sized so that both the PV module and the conductor from the module to the overcurrent device are properly protected [690.9 (A), 240.20 (A)]. PV modules must be protected so that the maximum series fuse rating, printed on the listing label, is not exceeded. It is important to note that even though the listing label states “fuse” rating, a more accurate term would be the “maximum series overcurrent protection” rating since either a fuse or a circuit breaker may be used to satisfy this listing requirement. The module may be protected either by installing fuses or circuit breakers in a series string of modules or by the design of the PV system.

Inverters listed with a Maximum utility back feed current that is well above 2 amps (typically equal to the maximum allowable output overcurrent protection) must be assumed to provide back feed current to the PV array. Each source circuit must have overcurrent protection that is greater than or equal to the minimum PV Source Circuit current rating and less than or equal to the maximum series fuse rating.

Explanation: For an array with a maximum source circuit current of 6.8 amps and a maximum series fuse rating of 15 amps, The minimum fuse rating would be 9 amps (next larger fuse rating above 8.5 amps; $6.8A \times 1.25 = 8.5A$) and the maximum would be 15 amps.

Inverters listed with a maximum utility back feed current that is 2 amps or less (e.g. Fronius IG 5100), two source circuits can be connected to the inverter without requiring overcurrent protection on either circuit.

Explanation: If an array containing two strings in parallel is connected to an inverter that is a limited back feeding source (2 amps or less), the maximum current in a string is equal to the current from the other string in parallel plus the maximum back-fed current from the inverter. If the maximum current of each string is 6.8 Amps, and the inverter provides 2 amps, then the maximum current in a fault at any PV module is 8.8 Amps and the maximum series fuse rating of the module will never be exceeded (i.e. a module with an I_{sc} of 5.4 amp will have a maximum series overcurrent device rating of at least 10 amps).

For smaller inverters listed with a maximum utility back feed current that is no larger than the module maximum overcurrent device rating (e.g. Enphase M200 with a 1.6 amp utility backfeed), a single source circuit can be connected to the inverter without requiring overcurrent protection on the array circuit.

Explanation: If a single string array (could be a single module array) is connected to an inverter that provides less than the rated module maximum overcurrent device rating in backfeed current, it is equivalent to having that size overcurrent device prevent current flow from the utility and the array is protected. The maximum reverse fault current at any PV module is the amount of the inverter utility backfeed current and the maximum series fuse rating of the module will never be exceeded.

Disconnecting Means:

The *NEC* defines disconnecting means in the follow way:

NEC Article 100 Disconnecting Means. A device, or group of devices, or other means by which the conductors of a circuit can be disconnected from their source of supply.

A primary purpose of a disconnecting means is to open a circuit providing a source of supply so that the equipment fed by that source can be maintained without exposing the operator to hazardous voltages (NFPA 70E).

Disconnecting Means in Inverters:

Various inverters have provided a variety of integral dc and ac disconnects. These disconnects may or may not provide the necessary isolation for maintenance. The key in differentiating whether the supplied disconnects provide the appropriate isolation is to review the primary method of maintenance and repair of the device. If the device has a standard means of removing the parts needing service, without exposing the technician to hazardous voltages (anything over 50 Volts), the supplied disconnects meet the intent of maintenance disconnecting means. If the technician is exposed to voltages above 50 Volts during service, even with the supplied disconnecting means, external disconnecting means may be necessary.

It is important to point out that every currently available PV inverter, that does not operate on a battery system, has input capacitors. These capacitors may remain energized for five or more minutes after all external sources are removed from an inverter. Internal bleed resistors remove this voltage over a prescribed time period, and warning labels are provided on the inverter to identify this hazard. This hazard is typical of electrical equipment using significant capacitance. This capacitive source is controlled by warning signage and bleed resistors and not generally by internal or external disconnects. Disconnects should not be required to control the capacitive source during maintenance or service of the inverter.

Utility-Required Disconnecting Means:

Utilities may require some method to isolate PV systems from their grid during maintenance procedures. The isolation device is usually required to provide a visible break in order to comply, and molded-case circuit breakers do not meet that requirement. Several utilities, including the utility with the most PV installations in the U.S., Pacific Gas & Electric, have adopted a policy of allowing residential PV systems with self-contained meters (the most common residential-type meter) to provide the necessary visible break via removal of the meter. For installations with current-transformer meters, a separate visible-break switch is almost always required. When the utility requires a visible-break switch, this switch may be used to provide the *NEC*-required ac switch for maintaining the inverter if the inverter is located in the immediate vicinity of the switch.

Provisions for the photovoltaic power source disconnecting means:

The 2005 *NEC* states in 690.14(C)(1), “Location. The photovoltaic disconnecting means shall be installed at a readily accessible location either outside of a building or structure or inside nearest the point of entrance of the system conductors. The photovoltaic system disconnecting means shall not be installed in bathrooms.”

- a) Readily accessible—*NEC* Article 100 states, “*Accessible, Readily (Readily Accessible). Capable of being reached quickly for operation, renewal, or inspections without requiring those to whom ready access is requisite to climb over or remove obstacles or to resort to portable ladders, and so forth.*”
- b) Readily accessible provision is primarily for emergency operation. If the disconnect is not mounted in close proximity of the service entrance disconnect (usually within 10 feet of the meter location or service disconnect switch), then a diagram or directory must be provided to clearly identify where the disconnecting means is located.
- c) A rooftop disconnect on a residential roof will normally not qualify as a readily accessible disconnect.

An exception to this requirement was added to the 2005 *NEC* to provide additional clarification for residential and building integrated PV systems. This exception reads:

“Exception: Installations that comply with 690.31(E) shall be permitted to have the disconnecting means located remote from the point of entry of the system conductors.”

NEC 690.31(E) states:

“(E) Direct-Current Photovoltaic Source and Output Circuits Inside a Building. Where direct current photovoltaic source or output circuits of a utility-interactive inverter from a building-integrated or other photovoltaic system are run inside a building or structure, they shall be contained in metallic raceways or enclosures from the point of penetration of the surface of the building or structure to the first readily accessible disconnecting means. The disconnecting means shall comply with 690.14(A) through 690.14(D).”

Although metal-clad cable is not specifically called out in 690.31(E), many jurisdictions consider installations with metal-clad cable as meeting the intent of this new provision. Note that this new section specifically mentions building-integrated systems. The way the 2002 *NEC* was written, a roof-integrated PV system cannot reasonably comply the 690.14(C)(1) as written.

APPENDIX D: COSTS OF PERMITS

Each jurisdiction may have different internal costs structures and approaches to working with solar PV systems. The following section is provided as a suggestion in developing the cost structure for a local jurisdiction.

Explanation: Costs for permits are often based on the overall project cost. This works well for many conventional projects because this accurately represents the scale of the project. However, with a PV installation, the equipment costs are much higher than with other projects of similar scope. It is therefore recommended that an alternative permit fee scale be used for PV system installations. The scope of a PV installation is similar to that of installing a retrofitted residential HVAC system. The permitting costs for a PV system should be similar to those for an HVAC system.

Although initial plan review and field inspection costs may be slightly higher for the first few systems, those costs should reduce as the local jurisdiction becomes familiar with the installations. A subdivision of more than 10 units should be considered for an additional fee reduction based on the repetitive nature of the reviews. A suggested fee schedule is as follows:

*Small PV system (up to 4 kW): \$75 - \$200
Large PV system (up to 10 kW): \$150 - \$400*

For systems of 10-50 kW, consider a permit cost of \$15 - \$40 per kW.

For systems of 50-100 kW, consider a permit cost of \$1,500.

For systems of 100-500 kW, consider a permit cost of \$3,000.

For systems up to 1000 kW, consider a permit cost of \$3,000-\$5,000.

APPENDIX E: TEMPERATURE TABLES

Design Temperatures For Various U.S. Cities

The following table indicates the 2% design temperature (averaged for June-August) for various cities; and the lowest expect ambient temperature [690.7] for each location (Min Mean Extreme Annual DB). The first column is elevation of the station for comparing climates with locations not listed. Column two represents the ASHRAE 2% design temperature(1). The third through sixth column is the resultant ambient temperature inside the conduit - unloaded(2). It is the temperature the wire is subjected to. The last column is the lowest expect ambient temperature for that city, based on 30 years of weather data. This is the temperature to be used for maximum voltage calculations in NEC 690.7. All temperatures in Celcius.

State	Station	Elev (M)	High	Temp. in Conduit in Sunlight (°C)				Extreme Annual DB	
			2%	Distance above roof.				Mean	
			DB	0"-0.5"	0.5"-3.5"	3.5"-12"	12"-36"	Max	Min
AK	BARROW	4	14	47	36	31	28	19	-43
AK	DEADHORSE	23	19	52	41	36	33	24	-45
AK	BARTER IS WSO AP	11	15	48	37	32	29	N/A	N/A
AK	KOTZEBUE	5	20	53	42	37	34	24	-39
AK	BETTLES	205	26	59	48	43	40	29	-47
AK	FORT YUKON	135	27	60	49	44	41	29	-48
AK	NOME	7	21	54	43	38	35	24	-37
AK	SAINT MARY'S (AWOS)	95	22	55	44	39	36	24	-34
AK	UNALAKLEET FIELD	4	21	54	43	38	35	N/A	N/A
AK	BETHEL	46	22	55	44	39	36	25	-35
AK	MCGRATH	103	25	58	47	42	39	28	-46
AK	TALKEETNA	105	24	57	46	41	38	27	-36
AK	KENAI MUNICIPAL AP	26	20	53	42	37	34	24	-33
AK	SOLDOTNA	33	21	54	43	38	35	24	-34
AK	NENANA MUNICIPAL AP	109	27	60	49	44	41	30	-46
AK	FAIRBANKS	138	27	60	49	44	41	31	-43
AK	EIELSON AFB	167	27	60	49	44	41	31	-44
AK	BIG DELTA	388	25	58	47	42	39	28	-47
AK	FT RICHARDSON/BRYANT APT	115	23	56	45	40	37	27	-31
AK	GULKANA	481	24	57	46	41	38	27	-45
AK	ELMENDORF AFB	65	23	56	45	40	37	25	-29
AK	ANCHORAGE	35	22	55	44	39	36	25	-26
AK	ANCHORAGE MERRILL FIELD	42	23	56	45	40	37	26	-26
AK	VALDEZ WSO	7	21	54	43	38	35	25	-17
AK	WHITTIER	9	21	54	43	38	35	23	-17
AK	SEWARD	18	21	54	43	38	35	26	-17
AK	NORTHWAY AIRPORT	522	26	59	48	43	40	28	-48
AK	CORDOVA	12	21	54	43	38	35	26	-23
AK	ST PAUL IS.	7	12	45	34	29	26	15	-19
AK	COLD BAY	29	15	48	37	32	29	19	-17
AK	DILLINGHAM (AMOS)	29	21	54	43	38	35	24	-34
AK	KING SALMON	15	22	55	44	39	36	25	-35
AK	PORT HEIDEN (AMOS)	29	18	51	40	35	32	N/A	N/A
AK	ILIAMNA ARPT	56	21	54	43	38	35	N/A	N/A
AK	HOMER ARPT	27	18	51	40	35	32	21	-21
AK	MIDDLETON ISLAND AUT	36	17	50	39	34	31	19	-10
AK	KODIAK	34	20	53	42	37	34	24	-17
AK	YAKUTAT	9	20	53	42	37	34	24	-21
AK	SITKA JAPONSKI AP	4	19	52	41	36	33	24	-11
AK	JUNEAU INT`L ARPT	3	23	56	45	40	37	27	-18
AK	WRANGELL	13	21	54	43	38	35	25	-13
AK	KETCHIKAN INTL AP	23	22	55	44	39	36	25	-14
AK	ANNETTE	34	23	56	45	40	37	27	-12
AK	SHEMYA	30	13	46	35	30	27	14	-8
AK	ADAK NAS	5	15	48	37	32	29	20	-11
AK	FIVE FINGER ISLAND	7	18	51	40	35	32	22	-9
AL	MOBILE	67	34	67	56	51	48	36	-7
AL	MONTGOMERY	62	36	69	58	53	50	37	-9

State	Station	Elev (M)	2%	0"-0.5"	0.5"-3.5"	3.5"-12"	12"-36"	Max	Min
AL	MAXWELL AFB	53	36	69	58	53	50	38	-6
AL	DOTHAN MUNICIPAL AP	97	35	68	57	52	49	37	-8
AL	CAIRNS FIELD FORT RUCKER	91	35	68	57	52	49	37	-8
AL	BIRMINGHAM	192	35	68	57	52	49	37	-12
AL	GADSEN MUNI (AWOS)	173	34	67	56	51	48	N/A	N/A
AL	TUSCALOOSA MUNICIPAL AP	51	36	69	58	53	50	37	-12
AL	ANNISTON METROPOLITAN AP	186	35	68	57	52	49	37	-12
AL	CENTREVILLE WSMO	140	34	67	56	51	48	36	-11
AL	HUNTSVILLE	190	35	68	57	52	49	36	-13
AL	MUSCLE SHOALS REGIONAL AP	164	35	68	57	52	49	37	-13
AL	DAUPHIN ISLAND	8	31	64	53	48	45	33	-2
AR	NORTH LITTLE ROCK	170	35	68	57	52	49	37	-12
AR	LITTLE ROCK ADAMS FIELD	78	37	70	59	54	51	39	-12
AR	LITTLE ROCK AFB	103	37	70	59	54	51	39	-13
AR	WALNUT RIDGE (AWOS)	83	35	68	57	52	49	38	-13
AR	JONESBORO MUNICIPAL	80	36	69	58	53	50	38	-16
AR	BLYTHEVILLE AFB	79	36	69	58	53	50	38	-15
AR	STUTTGART (AWOS)	68	36	69	58	53	50	38	-9
AR	PINE BLUFF FAA AP	63	36	69	58	53	50	38	-9
AR	TEXARKANA WEBB FIELD	110	37	70	59	54	51	39	-10
AR	EL DORADO GOODWIN FIELD	76	37	70	59	54	51	39	-9
AR	FORT SMITH	141	37	70	59	54	51	39	-14
AR	BENTONVILLE (AWOS)	395	34	67	56	51	48	36	-17
AR	FAYETTEVILLE DRAKE FIELD	381	35	68	57	52	49	37	-18
AR	HARRISON FAA AP	418	35	68	57	52	49	37	-16
AR	FLIPPIN (AWOS)	350	36	69	58	53	50	N/A	N/A
AR	BATESVILLE (AWOS)	141	37	70	59	54	51	38	-13
AR	ROGERS (AWOS)	415	34	67	56	51	48	37	-16
AZ	DOUGLAS BISBEE-DOUGLAS IN	1249	37	70	59	54	51	40	-9
AZ	TUCSON	779	41	74	63	58	55	43	-3
AZ	DAVIS MONTHAN AFB	808	40	73	62	57	54	43	-2
AZ	SAFFORD (AMOS)	950	40	73	62	57	54	42	-10
AZ	PHOENIX	339	43	76	65	60	57	46	0
AZ	LUKE AFB	331	44	77	66	61	58	47	-1
AZ	YUMA INTL ARPT	62	44	77	66	61	58	47	2
AZ	KINGMAN (AMOS)	1033	38	71	60	55	52	40	-8
AZ	PAGE MUNI (AMOS)	1304	37	70	59	54	51	40	-9
AZ	PRESCOTT LOVE FIELD	1536	35	68	57	52	49	37	-13
AZ	WINSLOW MUNICIPAL AP	1490	36	69	58	53	50	39	-15
AZ	FLAGSTAFF	2135	30	63	52	47	44	32	-22
CA	EL TORO MCAS	116	33	66	55	50	47	38	3
CA	TUSTIN MCAF	18	34	67	56	51	48	39	2
CA	MARCH AFB	462	38	71	60	55	52	42	-2
CA	ONTARIO	303	38	71	60	55	52	42	-1
CA	NORTON AFB/SAN BERN	353	39	72	61	56	53	43	-2
CA	BURBANK-GLENDALE-PASADENA	225	37	70	59	54	51	41	1
CA	SAN LUIS OBISPO	64	31	64	53	48	45	37	-2
CA	SAN DIEGO	9	29	62	51	46	43	34	5
CA	SAN DIEGO NORTH ISLAND NA	14	28	61	50	45	42	34	5
CA	CAMP PENDLETON MCAS	22	34	67	56	51	48	39	-3
CA	SAN DIEGO MIRAMAR NAS	139	33	66	55	50	47	38	1
CA	LOS ANGELES	32	29	62	51	46	43	35	4
CA	LONG BEACH	17	33	66	55	50	47	39	2
CA	EDWARDS AFB	705	41	74	63	58	55	44	-10
CA	DAGGETT	588	42	75	64	59	56	45	-5
CA	LANCASTER GEN WM FOX FIEL	712	39	72	61	56	53	42	-9
CA	GEORGE AFB	869	38	71	60	55	52	41	-6
CA	SANDBERG	1376	33	66	55	50	47	35	-6
CA	BAKERSFIELD	150	40	73	62	57	54	43	-2
CA	FRESNO	100	40	73	62	57	54	42	-3
CA	VISALIA MUNI (AWOS)	89	38	71	60	55	52	40	-3

State	Station	Elev (M)	2%	0"-0.5"	0.5"-3.5"	3.5"-12"	12"-36"	Max	Min
CA	PT.PIEDRAS BLANCA	21	26	59	48	43	40	N/A	N/A
CA	POINT MUGU NF	3	28	61	50	45	42	34	2
CA	SANTA BARBARA MUNICIPAL A	2	29	62	51	46	43	35	-1
CA	SANTA MARIA	72	29	62	51	46	43	35	-3
CA	PASO ROBLES MUNICIPAL ARP	243	39	72	61	56	53	43	-6
CA	BISHOP AIRPORT	1250	38	71	60	55	52	41	-14
CA	CASTLE AFB	60	38	71	60	55	52	40	-3
CA	SACRAMENTO	8	38	71	60	55	52	41	-3
CA	MATHER FIELD	29	38	71	60	55	52	41	-3
CA	MCCLELLAN AFB	25	39	72	61	56	53	42	-3
CA	BEALE AFB	38	38	71	60	55	52	41	-3
CA	SACRAMENTO METROPOLITAN A	7	38	71	60	55	52	41	-3
CA	SALINAS MUNICIPAL AP	21	28	61	50	45	42	35	-1
CA	STOCKTON METROPOLITAN ARP	6	38	71	60	55	52	41	-3
CA	OAKLAND METROPOLITAN ARPT	1	28	61	50	45	42	33	1
CA	SAN FRANCISCO	5	28	61	50	45	42	35	1
CA	SAN JOSE INTL AP	15	34	67	56	51	48	38	0
CA	BLUE CANYON AP	1609	29	62	51	46	43	31	-9
CA	UKIAH MUNICIPAL AP	188	38	71	60	55	52	42	-3
CA	RED BLUFF MUNICIPAL ARPT	106	41	74	63	58	55	44	-4
CA	REDDING MUNICIPAL ARPT	153	41	74	63	58	55	44	-5
CA	EUREKA	18	20	53	42	37	34	N/A	N/A
CA	ARCATA	69	21	54	43	38	35	28	-3
CA	MOUNT SHASTA	1077	33	66	55	50	47	35	-12
CA	ALAMEDA NAS	4	29	62	51	46	43	34	3
CA	MOUNTAIN VIEW MOFFETT FLD	11	31	64	53	48	45	36	0
CA	TRAVIS FIELD AFB	18	37	70	59	54	51	41	-3
CA	LEMOORE REEVES NAS	73	40	73	62	57	54	42	-3
CA	IMPERIAL	17	44	77	66	61	58	47	-1
CA	PALM SPRINGS THERMAL AP	34	44	77	66	61	58	48	-5
CA	BLYTHE RIVERSIDE CO ARPT	118	45	78	67	62	59	48	-1
CA	POINT ARENA	12	17	50	39	34	31	21	1
CA	POINT ARGUELLO	23	22	55	44	39	36	N/A	N/A
CO	ALAMOSA	2297	29	62	51	46	43	32	-31
CO	LA JUNTA MUNICIPAL AP	1281	38	71	60	55	52	40	-22
CO	PUEBLO	1439	37	70	59	54	51	39	-23
CO	TRINIDAD LAS ANIMAS COUNT	1751	34	67	56	51	48	37	-22
CO	COLORADO SPRGS	1881	32	65	54	49	46	35	-23
CO	LIMON	1695	33	66	55	50	47	35	-24
CO	DENVER/CENTENNIAL	1793	33	66	55	50	47	36	-23
CO	EAGLE	1985	31	64	53	48	45	34	-29
CO	DENVER STAPLETON INT'L AR	1611	34	67	56	51	48	37	-25
CO	AURORA BUCKLEY FIELD ANGB	1726	34	67	56	51	48	37	-22
CO	FORT COLLINS (SAWRS)	1525	32	65	54	49	46	35	-23
CO	AKRON WASHINGTON CO AP	1421	35	68	57	52	49	37	-23
CO	GRAND JUNCTION	1475	36	69	58	53	50	38	-18
CO	FORT COLLINS (AWOS)	1529	34	67	56	51	48	37	-23
CO	CRAIG-MOFFAT (AMOS)	1915	32	65	54	49	46	34	-32
CO	HAYDEN/YAMPA (AWOS)	2012	30	63	52	47	44	N/A	N/A
CT	BRIDGEPORT	2	31	64	53	48	45	34	-15
CT	HARTFORD	55	33	66	55	50	47	36	-20
CT	HARTFORD BRAINARD FD	6	33	66	55	50	47	N/A	N/A
DE	DOVER AFB	7	34	67	56	51	48	36	-14
DE	WILMINGTON	24	33	66	55	50	47	36	-16
FL	KEY WEST	1	33	66	55	50	47	33	10
FL	KEY WEST NAS	7	32	65	54	49	46	34	10
FL	MIAMI	2	33	66	55	50	47	35	4
FL	FORT LAUDERDALE HOLLYWOOD	3	34	67	56	51	48	36	4
FL	HOMESTEAD AFB	4	33	66	55	50	47	35	4
FL	MIAMI/KENDALL-TAMIA	3	34	67	56	51	48	36	4
FL	W PALM BEACH	6	33	66	55	50	47	35	2

State	Station	Elev (M)	2%	0"-0.5"	0.5"-3.5"	3.5"-12"	12"-36"	Max	Min
FL	MELBOURNE REGIONAL AP	10	34	67	56	51	48	36	-1
FL	VERO BEACH MUNICIPAL ARPT	7	33	66	55	50	47	36	0
FL	ORLANDO INTL ARPT	29	34	67	56	51	48	36	-1
FL	ORLANDO EXECUTIVE AP	32	34	67	56	51	48	36	0
FL	DAYTONA BEACH	12	34	67	56	51	48	36	-2
FL	ORLANDO SANFORD AIRPORT	16	35	68	57	52	49	36	0
FL	JACKSONVILLE	9	35	68	57	52	49	37	-5
FL	JACKSONVILLE NAS	9	35	68	57	52	49	37	-4
FL	MAYPORT NS	4	35	68	57	52	49	37	-3
FL	JACKSONVILLE CECIL FLD NA	27	36	69	58	53	50	37	-6
FL	JACKSONVILLE/CRAIG	12	34	67	56	51	48	36	-4
FL	FORT MYERS PAGE FIELD	4	35	68	57	52	49	36	1
FL	FT MYERS/SW FLORIDA	9	34	67	56	51	48	36	1
FL	TAMPA	3	34	67	56	51	48	35	-1
FL	SARASOTA-BRADENTON	9	34	67	56	51	48	36	0
FL	SAINT PETERSBURG	3	34	67	56	51	48	35	1
FL	CROSS CITY AIRPORT	11	35	68	57	52	49	N/A	N/A
FL	TALLAHASSEE	21	35	68	57	52	49	37	-8
FL	GAINESVILLE REGIONAL AP	40	34	67	56	51	48	36	-5
FL	APALACHICOLA MUNI AP	6	33	66	55	50	47	35	-5
FL	VALPARAISO ELGIN AFB	20	34	67	56	51	48	36	-7
FL	CRESTVIEW BOB SIKES AP	57	35	68	57	52	49	37	-9
FL	PENSACOLA REGIONAL AP	34	35	68	57	52	49	37	-6
FL	PENSACOLA FOREST SHERMAN	10	34	67	56	51	48	37	-6
FL	WHITING FIELD NAAS	53	35	68	57	52	49	37	-7
FL	TYNDALL AFB	7	33	66	55	50	47	35	-4
FL	VALPARAISO HURLBURT	11	34	67	56	51	48	36	-5
FL	MACDILL AFB	7	34	67	56	51	48	36	1
FL	NASA SHUTTLE FCLTY	3	34	67	56	51	48	36	-1
FL	VENICE PIER	2	31	64	53	48	45	N/A	N/A
FL	CAPE SAN BLAS	2	30	63	52	47	44	32	-2
FL	SETTLEMENT POINT	2	31	64	53	48	45	31	12
FL	ST. AUGUSTINE	8	33	66	55	50	47	34	0
FL	MOLASSES REEF	0	30	63	52	47	44	31	9
GA	SAVANNAH	16	35	68	57	52	49	37	-7
GA	WAYCROSS WARE CO AP	42	36	69	58	53	50	38	-5
GA	BRUNSWICK MALCOLM MCKINNO	4	34	67	56	51	48	36	-6
GA	ALBANY DOUGHERTY COUNTY A	57	36	69	58	53	50	38	-8
GA	VALDOSTA WB AIRPORT	61	35	68	57	52	49	38	-7
GA	MACON	110	36	69	58	53	50	38	-10
GA	WARNER ROBINS AFB	92	36	69	58	53	50	38	-9
GA	AUGUSTA	45	36	69	58	53	50	38	-10
GA	ATLANTA	315	34	67	56	51	48	36	-12
GA	ATLANTA/FULTON CO.	256	35	68	57	52	49	36	-12
GA	FORT BENNING LAWSON	88	36	69	58	53	50	38	-10
GA	COLUMBUS	136	36	69	58	53	50	37	-9
GA	MARIETTA DOBBINS AFB	330	34	67	56	51	48	36	-12
GA	ATHENS	244	35	68	57	52	49	37	-11
GA	ROME R B RUSSELL AP	194	35	68	57	52	49	37	-11
GA	HUNTER (AAF)	13	35	68	57	52	49	38	-5
GA	MOODY AFB/VALDOSTA	71	35	68	57	52	49	37	-7
HI	LIHUE	45	30	63	52	47	44	31	14
HI	KANEOHE BAY MCAS	3	30	63	52	47	44	31	17
HI	BARBERS POINT NAS	14	33	66	55	50	47	34	13
HI	HONOLULU	5	32	65	54	49	46	33	14
HI	MOLOKAI (AMOS)	137	31	64	53	48	45	33	13
HI	KAHULUI	15	32	65	54	49	46	33	13
HI	HILO	11	30	63	52	47	44	31	15
IA	CEDAR RAPIDS MUNICIPAL AP	256	33	66	55	50	47	35	-27
IA	BURLINGTON MUNICIPAL AP	210	34	67	56	51	48	36	-24
IA	DES MOINES	294	34	67	56	51	48	37	-26

State	Station	Elev (M)	2%	0"-0.5"	0.5"-3.5"	3.5"-12"	12"-36"	Max	Min
IA	OTTUMWA INDUSTRIAL AP	256	34	67	56	51	48	37	-24
IA	ANKENY REGIONAL ARP	342	35	68	57	52	49	36	-22
IA	DUBUQUE REGIONAL AP	321	32	65	54	49	46	34	-27
IA	CLINTON MUNI (AWOS)	216	32	65	54	49	46	35	-26
IA	WATERLOO	265	33	66	55	50	47	36	-29
IA	MASON CITY	373	33	66	55	50	47	36	-29
IA	FORT DODGE (AWOS)	355	33	66	55	50	47	36	-28
IA	SIOUX CITY	336	34	67	56	51	48	37	-27
IA	SPENCER	408	33	66	55	50	47	36	-28
ID	POCATELLO	1365	34	67	56	51	48	37	-25
ID	ELK CITY (RAMOS)	1249	34	67	56	51	48	37	-17
ID	IDAHO FALLS FANNING FIELD	1441	33	66	55	50	47	36	-27
ID	BURLEY MUNICIPAL ARPT	1267	35	68	57	52	49	38	-21
ID	BOISE	874	36	69	58	53	50	40	-19
ID	MOUNTAIN HOME AFB	912	37	70	59	54	51	41	-19
ID	LEWISTON NEZ PERCE CNTY A	437	36	69	58	53	50	40	-14
ID	CHALLIS (AMOS)	1529	33	66	55	50	47	N/A	N/A
ID	COEUR D'ALENE (AWOS)	707	33	66	55	50	47	35	-17
ID	MULLAN (AWRS)	1011	31	64	53	48	45	34	-21
IL	MOUNT VERNON (AWOS)	146	34	67	56	51	48	36	-22
IL	BELLEVILLE SCOTT AFB	135	35	68	57	52	49	38	-20
IL	SPRINGFIELD	187	34	67	56	51	48	36	-24
IL	QUINCY MUNI BALDWIN FLD	232	34	67	56	51	48	36	-23
IL	CHICAGO	190	33	66	55	50	47	36	-24
IL	W. CHICAGO/DU PAGE	231	33	66	55	50	47	35	-25
IL	GLENVIEW NAS	196	34	67	56	51	48	36	-24
IL	CHAMPAIGN/URBANA	230	34	67	56	51	48	36	-24
IL	DECATUR AIRPORT	208	34	67	56	51	48	36	-23
IL	PEORIA	199	34	67	56	51	48	36	-25
IL	STERLING ROCKFALLS	197	32	65	54	49	46	35	-25
IL	CHICAGO MIDWAY AP	186	34	67	56	51	48	36	-23
IL	ROCKFORD	221	33	66	55	50	47	35	-27
IL	MOLINE	181	34	67	56	51	48	36	-26
IL	MARSEILLES (AMOS)	225	34	67	56	51	48	35	-25
IN	EVANSVILLE	118	35	68	57	52	49	36	-19
IN	TERRE HAUTE HULMAN REGION	175	34	67	56	51	48	36	-23
IN	INDIANAPOLIS	246	33	66	55	50	47	35	-23
IN	LAFAYETTE PURDUE UNIV AP	182	34	67	56	51	48	36	-24
IN	FORT WAYNE	252	33	66	55	50	47	35	-24
IN	GRISSOM AFB/PERU	247	34	67	56	51	48	36	-23
IN	SOUTH BEND	236	33	66	55	50	47	35	-23
KS	WICHITA	408	38	71	60	55	52	41	-19
KS	MCCONNELL AFB	413	38	71	60	55	52	40	-18
KS	DODGE CITY	787	38	71	60	55	52	40	-21
KS	GARDEN CITY MUNICIPAL AP	878	37	70	59	54	51	40	-21
KS	LIBERAL MUNI (AWOS)	879	38	71	60	55	52	N/A	N/A
KS	GREAT BEND (AWOS)	575	37	70	59	54	51	41	-19
KS	HAYS MUNI (AWOS)	609	38	71	60	55	52	41	-20
KS	MEDICINE LODGE ASOS	467	39	72	61	56	53	42	-17
KS	FORT RILEY MARSHALL AAF	324	38	71	60	55	52	40	-20
KS	TOPEKA	270	36	69	58	53	50	38	-22
KS	TOPEKA FORBES FIELD	325	36	69	58	53	50	39	-22
KS	CONCORDIA BLOSSER MUNI AP	447	37	70	59	54	51	40	-22
KS	RUSSELL MUNICIPAL AP	566	38	71	60	55	52	41	-21
KS	SALINA MUNICIPAL AP	385	38	71	60	55	52	41	-21
KS	GOODLAND	1124	36	69	58	53	50	38	-24
KY	COVINGTON (CIN)	271	33	66	55	50	47	35	-21
KY	LEXINGTON	301	33	66	55	50	47	35	-19
KY	LOUISVILLE	149	34	67	56	51	48	36	-18
KY	LOUISVILLE BOWMAN FIELD	164	34	67	56	51	48	36	-18
KY	JACKSON JULIAN CARROLL AP	416	32	65	54	49	46	34	-19

State	Station	Elev (M)	2%	0"-0.5"	0.5"-3.5"	3.5"-12"	12"-36"	Max	Min
KY	FORT KNOX GODMAN AAF	239	34	67	56	51	48	36	-18
KY	PADUCAH BARKLEY REGIONAL	124	35	68	57	52	49	37	-17
KY	BOWLING GREEN WARREN CO A	160	34	67	56	51	48	36	-18
LA	NEW ORLEANS	3	34	67	56	51	48	36	-4
LA	NEW ORLEANS LAKEFRONT AP	2	34	67	56	51	48	36	-1
LA	NEW ORLEANS ALVIN CALLEND	1	34	67	56	51	48	36	-5
LA	BATON ROUGE	23	35	68	57	52	49	36	-6
LA	FORT POLK AAF	102	35	68	57	52	49	37	-7
LA	LAKE CHARLES	3	34	67	56	51	48	36	-5
LA	LAFAYETTE REGIONAL AP	11	35	68	57	52	49	36	-6
LA	SHREVEPORT	79	36	69	58	53	50	38	-8
LA	BARKSDALE AFB	53	36	69	58	53	50	37	-9
LA	MONROE REGIONAL AP	40	36	69	58	53	50	38	-8
LA	ENGLAND AFB	27	36	69	58	53	50	37	-7
LA	SOUTHWEST PASS	0	31	64	53	48	45	33	2
LA	GRAND ISLE	2	31	64	53	48	45	33	1
MA	OTIS ANGB	40	29	62	51	46	43	32	-16
MA	PROVINCETOWN (AWOS)	2	28	61	50	45	42	N/A	N/A
MA	BOSTON	5	33	66	55	50	47	36	-17
MA	WORCHESTER	301	30	63	52	47	44	32	-21
MA	SOUTH WEYMOUTH NAS	47	33	66	55	50	47	35	-19
MA	BUZZARDS BAY (LS)	0	24	57	46	41	38	N/A	N/A
MD	PATUXENT RIVER NAS	14	34	67	56	51	48	37	-13
MD	SALISBURY WICOMICO CO AP	15	34	67	56	51	48	36	-15
MD	BALTIMORE	47	34	67	56	51	48	37	-15
MD	ANDREWS AFB	86	35	68	57	52	49	37	-15
MD	THOMAS POINT	0	30	63	52	47	44	33	-11
ME	PORTLAND	19	30	63	52	47	44	34	-24
ME	BANGOR INTERNATIONAL AP	56	31	64	53	48	45	34	-27
ME	AUGUSTA AIRPORT	106	31	64	53	48	45	34	-24
ME	HOULTON INTL ARPT	150	30	63	52	47	44	34	-33
ME	CARIBOU	190	29	62	51	46	43	32	-31
ME	LORING AFB/LIMESTON	227	29	62	51	46	43	33	-29
ME	BRUNSWICK NAS	21	30	63	52	47	44	34	-25
ME	MATINICUS ISLAND	13	20	53	42	37	34	24	-18
MI	DETROIT METRO AP	191	32	65	54	49	46	35	-22
MI	DETROIT CITY AIRPORT	190	33	66	55	50	47	36	-19
MI	DETROIT WILLOW RUN AP	218	32	65	54	49	46	35	-20
MI	MOUNT CLEMENS SELFRIDGE F	176	32	65	54	49	46	35	-20
MI	HARBOR BEACH (RAMOS)	183	32	65	54	49	46	35	-17
MI	COPPER HARBOR RAMOS	186	27	60	49	44	41	N/A	N/A
MI	LANSING	256	32	65	54	49	46	35	-25
MI	JACKSON REYNOLDS FIELD	304	31	64	53	48	45	34	-23
MI	GRND RAPIDS	245	32	65	54	49	46	34	-23
MI	MUSKEGON	191	30	63	52	47	44	32	-21
MI	FLINT	233	32	65	54	49	46	34	-23
MI	PONTIAC-OAKLAND	299	32	65	54	49	46	N/A	N/A
MI	SAGINAW TRI CITY INTL AP	201	32	65	54	49	46	35	-22
MI	HOUGHTON LAKE	329	30	63	52	47	44	33	-27
MI	MANISTEE (AWOS)	189	29	62	51	46	43	32	-22
MI	TRAVERSE CITY	192	32	65	54	49	46	34	-24
MI	ALPENA	210	31	64	53	48	45	34	-27
MI	OSCODA WURTSMITH AFB	188	32	65	54	49	46	35	-22
MI	SEUL CHOIX PT (AMOS)	180	26	59	48	43	40	28	-22
MI	ESCANABA (AWOS)	187	28	61	50	45	42	31	-26
MI	SAULT STE.MARIE	221	29	62	51	46	43	32	-30
MI	CHIPPEWA INTL (AWOS)	244	28	61	50	45	42	32	-28
MI	PELLSTON EMMET COUNTY AP	217	31	64	53	48	45	34	-29
MI	MARQUETTE COUNTY ARPT	431	29	62	51	46	43	33	-30
MI	MARQUETTE SAWYER AFB	372	30	63	52	47	44	33	-28
MI	HANCOCK HOUGHTON CO AP	327	29	62	51	46	43	34	-24

State	Station	Elev (M)	2%	0"-0.5"	0.5"-3.5"	3.5"-12"	12"-36"	Max	Min
MI	IRONWOOD (AWOS)	375	30	63	52	47	44	33	-30
MI	STANNARD ROCK	183	24	57	46	41	38	27	-20
MN	ROCHESTER	402	31	64	53	48	45	35	-30
MN	SAINT CLOUD	313	32	65	54	49	46	35	-33
MN	MONTEVIDEO (AWOS)	315	32	65	54	49	46	35	-29
MN	REDWOOD FALLS MUNI	312	33	66	55	50	47	37	-30
MN	ALEXANDRIA MUNICIPAL AP	432	32	65	54	49	46	35	-32
MN	CLOQUET (AWOS)	390	29	62	51	46	43	32	-32
MN	FERGUS FALLS (AWOS)	361	32	65	54	49	46	36	-32
MN	FARIBAUT MUNI AWOS	322	32	65	54	49	46	34	-30
MN	MORRIS MUNI (AWOS)	344	31	64	53	48	45	34	-32
MN	PIPESTONE (AWOS)	529	31	64	53	48	45	34	-30
MN	NEW ULM MUNI (AWOS)	308	32	65	54	49	46	35	-29
MN	OWATONNA (AWOS)	350	32	65	54	49	46	34	-29
MN	WILLMAR	345	32	65	54	49	46	35	-31
MN	LITTLE FALLS (AWOS)	342	33	66	55	50	47	35	-34
MN	MINNEAPOLIS/ST.PAUL	255	33	66	55	50	47	36	-29
MN	LITCHFIELD MUNI	347	32	65	54	49	46	N/A	N/A
MN	MANKATO (AWOS)	311	32	65	54	49	46	N/A	N/A
MN	WORTHINGTON (AWOS)	480	31	64	53	48	45	N/A	N/A
MN	WINONA MUNI (AWOS)	200	33	66	55	50	47	N/A	N/A
MN	ALBERT LEA (AWOS)	383	31	64	53	48	45	34	-29
MN	DULUTH	432	29	62	51	46	43	32	-33
MN	CROOKSTON MUNI FLD	273	30	63	52	47	44	33	-34
MN	HIBBING CHISHOLM-HIBBING	410	30	63	52	47	44	33	-36
MN	GRAND RAPIDS (AWOS)	413	28	61	50	45	42	N/A	N/A
MN	ELY MUNI (AWOS)	443	29	62	51	46	43	33	-38
MN	INTERNATIONAL FALLS	361	30	63	52	47	44	33	-38
MN	EVELETH MUNI (AWOS)	421	30	63	52	47	44	32	-36
MN	MORA MUNI (AWOS)	309	31	64	53	48	45	N/A	N/A
MN	ROSEAU MUNI (AWOS)	323	29	62	51	46	43	N/A	N/A
MN	PEQUOT LAKE (AMOS)	390	32	65	54	49	46	35	-35
MN	AITKIN NDB (AWOS)	367	29	62	51	46	43	32	-35
MN	WHEATON NDB (AWOS)	313	32	65	54	49	46	35	-32
MN	BEMIDJI MUNICIPAL	420	31	64	53	48	45	33	-35
MN	TOFTE (RAMOS)	241	26	59	48	43	40	29	-29
MN	THIEF RIVER (AWOS)	340	29	62	51	46	43	N/A	N/A
MN	WARROAD (AMOS)	328	31	64	53	48	45	34	-37
MN	PASSAGE ISLAND	195	19	52	41	36	33	N/A	N/A
MO	POPLAR BLUFF (AMOS)	146	35	68	57	52	49	37	-17
MO	CAPE GIRARDEAU MUNICIPAL	102	35	68	57	52	49	37	-18
MO	JOPLIN MUNICIPAL AP	297	36	69	58	53	50	38	-18
MO	ST. LOUIS	172	35	68	57	52	49	37	-20
MO	ST LOUIS SPIRIT OF ST LOU	140	35	68	57	52	49	38	-20
MO	SPRINGFIELD	387	35	68	57	52	49	37	-20
MO	COLUMBIA	270	35	68	57	52	49	37	-22
MO	KIRKSVILLE REGIONAL AP	294	35	68	57	52	49	36	-23
MO	KAISER MEM (AWOS)	265	35	68	57	52	49	N/A	N/A
MO	KANSAS CITY	315	35	68	57	52	49	38	-22
MO	KANSAS CITY DOWNTOWN AP	226	36	69	58	53	50	39	-19
MO	WHITEMAN AFB	255	36	69	58	53	50	38	-20
MO	SPICKARD (AMOS)	270	36	69	58	53	50	N/A	N/A
MS	MERIDIAN	94	36	69	58	53	50	37	-10
MS	MERIDIAN NAAS	82	36	69	58	53	50	38	-11
MS	PINE BELT RGNL AWOS	91	36	69	58	53	50	37	-8
MS	JACKSON	101	36	69	58	53	50	37	-10
MS	MCCOMB PIKE COUNTY AP	125	35	68	57	52	49	37	-9
MS	GREENWOOD LEFLORE ARPT	47	36	69	58	53	50	38	-10
MS	COLUMBUS AFB	68	36	69	58	53	50	38	-11
MS	COLUMBUS GOLDEN TRIANGLE	80	36	69	58	53	50	37	-11
MS	TUPELO C D LEMONS ARPT	110	35	68	57	52	49	37	-11

State	Station	Elev (M)	2%	0"-0.5"	0.5"-3.5"	3.5"-12"	12"-36"	Max	Min
MS	KEESLER AFB	7	34	67	56	51	48	36	-6
MT	GLENDIVE (AWOS)	749	34	67	56	51	48	37	-31
MT	BILLINGS	1088	34	67	56	51	48	37	-27
MT	LEWISTOWN	1264	32	65	54	49	46	35	-32
MT	BUTTE BERT MOONEY ARPT	1688	31	64	53	48	45	33	-36
MT	BOZEMAN GALLATIN FIELD	1349	33	66	55	50	47	36	-33
MT	GLASGOW	700	34	67	56	51	48	37	-33
MT	JORDAN (RAMOS)	811	35	68	57	52	49	39	-38
MT	SIDNEY-RICHLAND	605	33	66	55	50	47	N/A	N/A
MT	HELENA	1188	33	66	55	50	47	36	-31
MT	MISSOULA	972	33	66	55	50	47	36	-26
MT	GREAT FALLS	1116	33	66	55	50	47	37	-31
MT	MALMSTROM AFB	1056	34	67	56	51	48	37	-30
MT	HAVRE CITY-COUNTY AP	787	35	68	57	52	49	38	-36
MT	KALISPELL	904	32	65	54	49	46	35	-28
MT	CUT BANK	1170	31	64	53	48	45	34	-33
MT	MILES CITY MUNICIPAL ARPT	801	37	70	59	54	51	40	-31
NC	WILMINGTON INTERNATIONAL	9	34	67	56	51	48	36	-9
NC	FAYETTEVILLE POPE AFB	66	36	69	58	53	50	38	-11
NC	CAPE HATTERAS	2	31	64	53	48	45	33	-6
NC	RALEIGH/DURHAM	134	34	67	56	51	48	36	-13
NC	GOLDSBORO SEYMOUR JOHNSON	33	36	69	58	53	50	38	-10
NC	CHERRY POINT MCAS	11	34	67	56	51	48	37	-9
NC	NEW BERN CRAVEN CO REGL A	4	34	67	56	51	48	37	-10
NC	NEW RIVER MCAF	4	34	67	56	51	48	37	-10
NC	CHARLOTTE	234	34	67	56	51	48	36	-11
NC	SOUTHERN PINES AWOS	141	35	68	57	52	49	N/A	N/A
NC	HICKORY REGIONAL AP	348	34	67	56	51	48	36	-13
NC	ASHEVILLE	661	31	64	53	48	45	33	-16
NC	GREENSBORO	270	34	67	56	51	48	36	-14
NC	WINSTON-SALEM REYNOLDS AP	295	34	67	56	51	48	36	-12
NC	FORT BRAGG SIMMONS AAF	93	36	69	58	53	50	38	-10
NC	DIAMOND SHOALS (LS)	0	29	62	51	46	43	30	-3
NC	FRYING PAN SHOALS	0	29	62	51	46	43	29	-1
NC	CAPE LOOKOUT	2	29	62	51	46	43	31	-6
ND	FARGO	274	33	66	55	50	47	36	-32
ND	LIDGERWOOD (RAMOS)	351	33	66	55	50	47	37	-31
ND	JAMESTOWN MUNICIPAL ARPT	454	33	66	55	50	47	36	-31
ND	GRAND FORKS AF	276	33	66	55	50	47	37	-32
ND	GRAND FORKS INTERNATIONAL	255	32	65	54	49	46	36	-33
ND	DEVILS LAKE (AMOS)	442	32	65	54	49	46	35	-33
ND	BISMARCK	502	34	67	56	51	48	38	-34
ND	DICKINSON MUNICIPAL AP	787	34	67	56	51	48	38	-32
ND	WILLISTON SLOULIN INTL AP	580	35	68	57	52	49	38	-34
ND	MINOT AFB	497	34	67	56	51	48	38	-33
ND	MINOT	522	33	66	55	50	47	37	-31
NE	OMAHA EPPLEY AIRFIELD	299	35	68	57	52	49	37	-25
NE	LINCOLN MUNICIPAL ARPT	356	36	69	58	53	50	39	-25
NE	GRAND ISLAND	566	36	69	58	53	50	39	-25
NE	KEARNEY MUNI (AWOS)	649	34	67	56	51	48	37	-23
NE	OMAHA	404	35	68	57	52	49	38	-26
NE	BELLEVUE OFFUTT AFB	319	35	68	57	52	49	38	-23
NE	NORFOLK	471	35	68	57	52	49	38	-26
NE	COLUMBUS MUNI (AWOS)	440	34	67	56	51	48	36	-25
NE	SIDNEY MUNICIPAL AP	1313	35	68	57	52	49	38	-26
NE	NORTH PLATTE	849	35	68	57	52	49	38	-26
NE	SCOTTSBLUFF	1206	36	69	58	53	50	39	-28
NE	VALENTINE MILLER FIELD	789	36	69	58	53	50	40	-30
NH	CONCORD	105	32	65	54	49	46	35	-27
NH	PEASE AFB/PORTSMOUT	31	32	65	54	49	46	34	-19
NH	LEBANON MUNICIPAL	182	31	64	53	48	45	34	-27

State	Station	Elev (M)	2%	0"-0.5"	0.5"-3.5"	3.5"-12"	12"-36"	Max	Min
NH	MOUNT WASHINGTON	1910	16	49	38	33	30	19	-36
NH	MANCHESTER AIRPORT	68	33	66	55	50	47	36	-21
NH	ISLE OF SHOALS (LS)	7	27	60	49	44	41	31	-17
NJ	ATLANTIC CITY	20	33	66	55	50	47	36	-17
NJ	MILLVILLE MUNICIPAL AP	21	33	66	55	50	47	36	-17
NJ	MCGUIRE AFB	45	34	67	56	51	48	36	-16
NJ	NEWARK	9	34	67	56	51	48	37	-15
NJ	TETERBORO AIRPORT	2	34	67	56	51	48	36	-16
NM	ROSWELL INDUSTRIAL AIR PA	1112	38	71	60	55	52	40	-14
NM	CLOVIS CANNON AFB	1309	36	69	58	53	50	39	-14
NM	CARLSBAD CAVERN CITY AIR	985	39	72	61	56	53	42	-11
NM	WHITE SANDS TEST RG	1244	37	70	59	54	51	40	-12
NM	TRUTH OR CONSEQUENCES MUN	1478	37	70	59	54	51	39	-10
NM	CLAYTON MUNICIPAL AIRPARK	1511	35	68	57	52	49	37	-19
NM	GALLUP SEN CLARKE FLD	1970	33	66	55	50	47	35	-23
NM	ALBUQUERQUE	1619	36	69	58	53	50	38	-13
NM	FARMINGTON FOUR CORNERS R	1674	35	68	57	52	49	37	-17
NM	TAOS MUNI APT (AWOS)	2161	31	64	53	48	45	N/A	N/A
NM	TUCUMCARI	1231	37	70	59	54	51	39	-17
NM	HOLLOMAN AFB	1248	37	70	59	54	51	39	-11
NV	LAS VEGAS	664	42	75	64	59	56	44	-5
NV	NELLIS AFB	573	43	76	65	60	57	45	-6
NV	TONOPAH	1653	35	68	57	52	49	37	-17
NV	ELY	1906	32	65	54	49	46	35	-25
NV	CALIENTE (AMOS)	1335	37	70	59	54	51	N/A	N/A
NV	RENO	1341	35	68	57	52	49	38	-16
NV	FALLON NAAS	1199	37	70	59	54	51	N/A	N/A
NV	LOVELOCK DERBY FIELD	1188	37	70	59	54	51	39	-20
NV	ELKO	1547	35	68	57	52	49	37	-24
NV	WINNEMUCCA	1323	36	69	58	53	50	39	-22
NY	NEW YORK LAGUARDIA ARPT	3	33	66	55	50	47	36	-14
NY	ISLIP LONG ISL MACARTHUR	25	31	64	53	48	45	35	-16
NY	POUGHKEEPSIE DUTCHESS CO	47	33	66	55	50	47	36	-23
NY	WHITE PLAINS WESTCHESTER	121	32	65	54	49	46	35	-17
NY	STEWART FIELD	177	32	65	54	49	46	34	-20
NY	BINGHAMTON	499	30	63	52	47	44	32	-22
NY	ELMIRA CORNING REGIONAL A	291	32	65	54	49	46	35	-23
NY	ALBANY	89	31	64	53	48	45	34	-24
NY	GLENS FALLS AP	97	31	64	53	48	45	34	-29
NY	SYRACUSE	124	31	64	53	48	45	34	-24
NY	GRIFFISS AFB	158	32	65	54	49	46	34	-26
NY	UTICA ONEIDA COUNTY AP	217	31	64	53	48	45	33	-25
NY	JAMESTOWN (AWOS)	525	28	61	50	45	42	31	-21
NY	BUFFALO	215	30	63	52	47	44	32	-20
NY	NIAGARA FALLS AF	180	31	64	53	48	45	33	-20
NY	ROCHESTER	169	31	64	53	48	45	34	-21
NY	MASSENA AP	65	31	64	53	48	45	33	-32
NY	PLATTSBURGH AFB	71	30	63	52	47	44	34	-28
NY	WATERTOWN AP	96	30	63	52	47	44	32	-32
NY	FORT DRUM/WHEELER	211	30	63	52	47	44	33	-29
NY	NEW YORK J F KENNEDY INT`	4	32	65	54	49	46	36	-14
NY	DUNKIRK	183	27	60	49	44	41	31	-16
NY	GALLOO ISLAND	76	26	59	48	43	40	28	-22
OH	COLUMBUS	254	33	66	55	50	47	35	-20
OH	COLUMBUS RICKENBACKE	230	34	67	56	51	48	36	-19
OH	ZANESVILLE MUNICIPAL AP	268	32	65	54	49	46	35	-21
OH	DAYTON	306	33	66	55	50	47	35	-22
OH	CINCINNATI MUNICIPAL AP L	149	34	67	56	51	48	36	-19
OH	AKRON/CANTON	377	31	64	53	48	45	33	-22
OH	CLEVELAND	245	32	65	54	49	46	34	-21
OH	MANSFIELD	395	31	64	53	48	45	33	-22

State	Station	Elev (M)	2%	0"-0.5"	0.5"-3.5"	3.5"-12"	12"-36"	Max	Min
OH	YOUNGSTOWN	361	31	64	53	48	45	33	-21
OH	TOLEDO	211	33	66	55	50	47	35	-23
OH	FINDLAY AIRPORT	243	32	65	54	49	46	34	-22
OH	DAYTON WRIGHT PATTERSON A	249	33	66	55	50	47	35	-21
OK	ALTUS AFB	413	40	73	62	57	54	42	-13
OK	HOBART MUNICIPAL AP	478	39	72	61	56	53	42	-14
OK	GAGE AIRPORT	667	38	71	60	55	52	40	-19
OK	OKLAHOMA CITY	397	38	71	60	55	52	39	-15
OK	VANCE AFB/ENID	398	38	71	60	55	52	41	-16
OK	OKLAHOMA CITY TINKER AFB	384	37	70	59	54	51	39	-14
OK	OKLAHOMA CITY/WILEY	396	38	71	60	55	52	40	-15
OK	PONCA CITY MUNICIPAL AP	304	38	71	60	55	52	41	-15
OK	FORT SILL POST FIELD AF	369	38	71	60	55	52	40	-13
OK	TULSA	206	38	71	60	55	52	40	-16
OK	MCALESTER MUNICIPAL AP	231	37	70	59	54	51	39	-14
OR	KLAMATH FALLS INTL AP	1244	33	66	55	50	47	36	-17
OR	MEDFORD	396	37	70	59	54	51	40	-9
OR	SEXTON SUMMIT	1168	28	61	50	45	42	31	-8
OR	BURNS	1271	33	66	55	50	47	36	-25
OR	REDMOND	940	34	67	56	51	48	37	-20
OR	BURNS MUNICIPAL ARPT	1261	33	66	55	50	47	36	-29
OR	PENDLETON	456	36	69	58	53	50	39	-17
OR	MEACHAM	1236	30	63	52	47	44	33	-31
OR	BAKER MUNICIPAL AP	1026	34	67	56	51	48	37	-23
OR	NORTH BEND	5	22	55	44	39	36	28	-5
OR	EUGENE	109	33	66	55	50	47	37	-9
OR	SALEM	61	33	66	55	50	47	37	-9
OR	CORVALLIS MUNI AWOS	75	33	66	55	50	47	38	-8
OR	PORTLAND	12	33	66	55	50	47	37	-7
OR	PORTLAND/HILLSBORO	62	33	66	55	50	47	37	-9
OR	ASTORIA	7	25	58	47	42	39	30	-7
OR	CAPE ARAGO (LS)	18	19	52	41	36	33	23	-1
OR	NEWPORT STATE BEACH	9	19	52	41	36	33	28	-2
PA	PHILADELPHIA	9	34	67	56	51	48	36	-15
PA	PHILADELPHIA NE PHILADELP	30	34	67	56	51	48	37	-15
PA	WILLOW GROVE NAS	102	34	67	56	51	48	36	-17
PA	READING SPAATZ FIELD	103	33	66	55	50	47	N/A	N/A
PA	MIDDLETOWN HARRISBURG INT	92	34	67	56	51	48	37	-16
PA	WASHINGTON (AWOS)	361	31	64	53	48	45	N/A	N/A
PA	HARRISBURG CAPITAL CITY A	103	34	67	56	51	48	36	-17
PA	BUTLER CO. (AWOS)	380	31	64	53	48	45	N/A	N/A
PA	DUBOIS FAA AP	552	30	63	52	47	44	32	-22
PA	ALTOONA BLAIR CO ARPT	451	32	65	54	49	46	34	-20
PA	JOHNSTOWN CAMBRIA COUNTY	694	30	63	52	47	44	32	-19
PA	WILKES-BARRE/S	289	31	64	53	48	45	34	-20
PA	WILLIAMSPORT	160	32	65	54	49	46	35	-20
PA	ALLENTOWN	117	33	66	55	50	47	35	-18
PA	PITTSBURGH	373	32	65	54	49	46	34	-20
PA	PITTSBURGH ALLEGHENY CO A	380	32	65	54	49	46	34	-19
PA	ERIE	225	30	63	52	47	44	33	-20
PA	BRADFORD	646	28	61	50	45	42	31	-26
RI	BLOCK ISLAND STATE ARPT	33	27	60	49	44	41	30	-14
RI	PROVIDENCE	19	32	65	54	49	46	36	-18
SC	CHARLESTON	12	35	68	57	52	49	37	-7
SC	BEAUFORT MCAS	10	35	68	57	52	49	38	-7
SC	COLUMBIA	69	36	69	58	53	50	38	-10
SC	FLORENCE REGIONAL AP	44	36	69	58	53	50	38	-10
SC	GREENVILLE	296	34	67	56	51	48	36	-11
SC	ANDERSON COUNTY AP	231	35	68	57	52	49	37	-10
SC	SUMTER SHAW AFB	74	35	68	57	52	49	38	-9
SC	MYRTLE BEACH AFB	7	34	67	56	51	48	36	-8

State	Station	Elev (M)	2%	0"-0.5"	0.5"-3.5"	3.5"-12"	12"-36"	Max	Min
SC	FOLLY BEACH	3	31	64	53	48	45	34	-3
SD	SIOUX FALLS	435	34	67	56	51	48	37	-30
SD	BROOKINGS (AWOS)	502	31	64	53	48	45	34	-30
SD	YANKTON (AWOS)	398	33	66	55	50	47	36	-27
SD	HURON	393	35	68	57	52	49	38	-31
SD	MITCHELL (AWOS)	397	33	66	55	50	47	36	-28
SD	WATERTOWN MUNICIPAL AP	532	32	65	54	49	46	N/A	N/A
SD	ABERDEEN REGIONAL ARPT	398	34	67	56	51	48	37	-33
SD	RAPID CITY	966	35	68	57	52	49	39	-27
SD	ELLSWORTH AFB	979	36	69	58	53	50	39	-26
SD	MOBRIDGE	508	34	67	56	51	48	38	-30
SD	PIERRE	526	37	70	59	54	51	41	-28
TN	BRISTOL	459	32	65	54	49	46	34	-18
TN	CHATTANOOGA	210	35	68	57	52	49	36	-13
TN	KNOXVILLE	299	34	67	56	51	48	35	-15
TN	CROSSVILLE MEMORIAL AP	569	32	65	54	49	46	33	-19
TN	NASHVILLE	180	35	68	57	52	49	36	-16
TN	MEMPHIS	87	36	69	58	53	50	37	-12
TN	MEMPHIS NAS	89	36	69	58	53	50	38	-14
TN	JACKSON MCKELLAR-SIPES RE	132	35	68	57	52	49	37	-15
TN	DYERSBURG MUNICIPAL AP	102	34	67	56	51	48	36	-12
TN	FORT CAMPBELL AAF	173	35	68	57	52	49	37	-17
TX	ABILENE DYESS AFB	545	39	72	61	56	53	41	-12
TX	PORT ARTHUR	7	34	67	56	51	48	36	-5
TX	GALVESTON/SCHOLES	16	33	66	55	50	47	35	0
TX	HOUSTON	33	36	69	58	53	50	38	-5
TX	HOUSTON WILLIAM P HOBBY A	13	35	68	57	52	49	37	-4
TX	HOUSTON ELLINGTON AFB	11	36	69	58	53	50	37	-3
TX	COLLEGE STATION EASTERWOOD	95	38	71	60	55	52	40	-7
TX	LUFKIN	96	36	69	58	53	50	38	-8
TX	BROWNSVILLE	6	35	68	57	52	49	37	0
TX	HARLINGEN RIO GRANDE VALL	10	37	70	59	54	51	39	0
TX	MCCALLEN MILLER INTL AP	30	38	71	60	55	52	41	-1
TX	CORPUS CHRISTI	13	35	68	57	52	49	37	-3
TX	CORPUS CHRISTI NAS	6	34	67	56	51	48	36	-1
TX	KINGSVILLE	17	37	70	59	54	51	39	-3
TX	ALICE INTL AP	52	38	71	60	55	52	40	-3
TX	LAREDO INTL AP	150	39	72	61	56	53	41	-2
TX	COTULLA FAA AP	141	39	72	61	56	53	N/A	N/A
TX	SAN ANTONIO	242	37	70	59	54	51	38	-7
TX	HONDO MUNICIPAL AP	280	37	70	59	54	51	39	-7
TX	SAN ANTONIO KELLY FIELD A	207	38	71	60	55	52	40	-7
TX	RANDOLPH AFB	231	38	71	60	55	52	39	-6
TX	AUSTIN	189	37	70	59	54	51	39	-7
TX	BERGSTROM AFB/AUSTI	165	38	71	60	55	52	39	-8
TX	VICTORIA	32	36	69	58	53	50	38	-5
TX	PALACIOS MUNICIPAL AP	4	33	66	55	50	47	36	-3
TX	BEEVILLE CHASE NAAS	60	38	71	60	55	52	40	-5
TX	WACO	155	38	71	60	55	52	40	-9
TX	KILLEEN MUNI (AWOS)	258	38	71	60	55	52	39	-6
TX	ROBERT GRAY AAF	312	38	71	60	55	52	39	-8
TX	TEMPLE/MILLER (AWOS)	208	38	71	60	55	52	40	-7
TX	DALLAS LOVE FIELD	134	38	71	60	55	52	40	-8
TX	DALLAS HENSLEY FIELD NAS	150	38	71	60	55	52	40	-9
TX	DALLAS/FORT WORTH INT AP	164	38	71	60	55	52	40	-10
TX	FORT WORTH/ALLIANCE	220	39	72	61	56	53	40	-8
TX	FORT WORTH NAS	185	38	71	60	55	52	40	-10
TX	FORT WORTH MEACHAM	209	38	71	60	55	52	40	-10
TX	STEPHENVILLE CLARK FIELD	398	36	69	58	53	50	38	-11
TX	DEL RIO INTERNATIONAL AP	304	39	72	61	56	53	41	-3
TX	DEL RIO LAUGHLIN AFB	327	40	73	62	57	54	41	-5

State	Station	Elev (M)	2%	0"-0.5"	0.5"-3.5"	3.5"-12"	12"-36"	Max	Min
TX	PINE SPRINGS GUADALUPE MO	1663	34	67	56	51	48	37	-12
TX	SAN ANGELO	582	38	71	60	55	52	40	-10
TX	DALHART MUNICIPAL AP	1216	36	69	58	53	50	38	-17
TX	MARFA AP	1473	34	67	56	51	48	37	-14
TX	MIDLAND/ODESSA	871	38	71	60	55	52	40	-12
TX	WINK WINKLER COUNTY AP	855	39	72	61	56	53	42	-11
TX	ABILENE	534	38	71	60	55	52	40	-12
TX	LUBBOCK	988	37	70	59	54	51	40	-14
TX	REESE AFB	1014	38	71	60	55	52	40	-14
TX	EL PASO	1194	39	72	61	56	53	41	-9
TX	WICHITA FALLS	314	39	72	61	56	53	42	-13
TX	CHILDRESS MUNICIPAL AP	594	39	72	61	56	53	42	-12
TX	AMARILLO	1098	36	69	58	53	50	38	-18
TX	SANDERSON (RAMOS)	865	37	70	59	54	51	40	-10
TX	JUNCTION KIMBLE COUNTY AP	533	38	71	60	55	52	40	-10
TX	PORT ARANSAS	5	30	63	52	47	44	31	-1
TX	SABINE	1	31	64	53	48	45	33	-4
UT	PRICE/CARBON (RAMOS)	1799	33	66	55	50	47	36	-20
UT	CEDAR CITY	1712	34	67	56	51	48	37	-21
UT	SALT LAKE CITY	1288	36	69	58	53	50	38	-17
UT	OGDEN HILL AFB	1459	34	67	56	51	48	36	-16
UT	WENDOVER USAF AUXILIARY F	1291	36	69	58	53	50	37	-17
VA	OCEANA NAS	7	34	67	56	51	48	36	-11
VA	NORFOLK	9	34	67	56	51	48	37	-10
VA	NORFOLK NAS	10	35	68	57	52	49	37	-9
VA	NEWPORT NEWS	13	35	68	57	52	49	37	-12
VA	RICHMOND	50	35	68	57	52	49	37	-14
VA	PETERSBURG (AWOS)	59	36	69	58	53	50	38	-15
VA	WASHINGTON-DULLES INTL AP	82	34	67	56	51	48	36	-18
VA	QUANTICO MCAS	4	34	67	56	51	48	36	-14
VA	MANASSAS MUNI (AWOS)	59	34	67	56	51	48	N/A	N/A
VA	DAVISON AAF	27	36	69	58	53	50	38	-17
VA	WASHINGTON DC REAGAN AP	3	35	68	57	52	49	37	-13
VA	LYNCHBURG	279	33	66	55	50	47	35	-15
VA	ROANOKE	358	33	66	55	50	47	35	-15
VA	LANGLEY AFB	3	34	67	56	51	48	36	-10
VT	RUTLAND STATE (AWOS)	240	29	62	51	46	43	32	-27
VT	MONTPELIER AP	343	30	63	52	47	44	32	-28
VT	BURLINGTON	104	31	64	53	48	45	34	-28
WA	WHIDBEY ISLAND NAS	10	22	55	44	39	36	26	-9
WA	YAKIMA	325	35	68	57	52	49	38	-18
WA	STAMPEDE PASS	1206	25	58	47	42	39	29	-15
WA	WENATCHEE/PANGBORN	379	35	68	57	52	49	38	-17
WA	HANFORD	223	38	71	60	55	52	41	-16
WA	PASCO	135	37	70	59	54	51	41	-15
WA	WALLA WALLA CITY COUNTY A	355	37	70	59	54	51	41	-15
WA	SPOKANE	721	34	67	56	51	48	36	-21
WA	FAIRCHILD AFB	743	33	66	55	50	47	36	-19
WA	SPOKANE/FELTS FIELD	595	35	68	57	52	49	38	-17
WA	PULLMAN/MOSCOW RGNL	778	34	67	56	51	48	36	-18
WA	PORT ANGELES INTL	88	26	59	48	43	40	N/A	N/A
WA	OLYMPIA	61	31	64	53	48	45	35	-12
WA	KELSO WB AP	4	30	63	52	47	44	N/A	N/A
WA	BREMERTON NTNL AWOS	147	29	62	51	46	43	34	-8
WA	SEATTLE/TACOMA	122	29	62	51	46	43	33	-7
WA	SEATTLE BOEING FIELD	6	30	63	52	47	44	34	-7
WA	QUILLAYUTE	55	27	60	49	44	41	32	-8
WA	BELLINGHAM INTL AP	45	26	59	48	43	40	30	-10
WA	TACOMA MCCHORD AFB	88	30	63	52	47	44	34	-11
WA	GRAY AAF	89	30	63	52	47	44	34	-10
WA	DESTRUCTION ISLAND	16	18	51	40	35	32	22	-2

State	Station	Elev (M)	2%	0"-0.5"	0.5"-3.5"	3.5"-12"	12"-36"	Max	Min
WA	SMITH ISLAND	15	19	52	41	36	33	23	-4
WA	TATOOSH ISLAND	31	18	51	40	35	32	22	-2
WA	WEST POINT (LS)	3	21	54	43	38	35	25	-3
WI	MILWAUKEE	211	32	65	54	49	46	35	-24
WI	MADISON	262	32	65	54	49	46	35	-27
WI	LA CROSSE	205	33	66	55	50	47	37	-28
WI	EAU CLAIRE	273	32	65	54	49	46	36	-31
WI	GREEN BAY	214	31	64	53	48	45	34	-28
WI	MANITOWAC MUNI AWOS	198	29	62	51	46	43	N/A	N/A
WI	WAUSAU MUNICIPAL ARPT	365	31	64	53	48	45	34	-29
WI	PHILLIPS/PRICE CO.	449	29	62	51	46	43	N/A	N/A
WI	PARK FALLS MUNI	469	29	62	51	46	43	N/A	N/A
WI	DEVIL'S ISLAND	192	26	59	48	43	40	31	-24
WI	SHEBOYGAN	176	29	62	51	46	43	33	-23
WV	BECKLEY RALEIGH CO MEM AP	763	29	62	51	46	43	31	-20
WV	BLUEFIELD/MERCER CO	871	29	62	51	46	43	31	-20
WV	CHARLESTON	290	33	66	55	50	47	35	-18
WV	ELKINS	594	30	63	52	47	44	32	-25
WV	MORGANTOWN HART FIELD	378	32	65	54	49	46	34	-19
WV	MARTINSBURG EASTERN WV RE	161	34	67	56	51	48	37	-18
WV	HUNTINGTON	255	33	66	55	50	47	35	-19
WV	PARKERSBURG WOOD COUNTY A	253	33	66	55	50	47	35	-20
WY	CHEYENNE	1872	31	64	53	48	45	34	-26
WY	LARAMIE GENERAL BRES FIE	2214	29	62	51	46	43	32	-31
WY	CASPER	1612	34	67	56	51	48	37	-30
WY	ROCK SPRINGS ARPT	2054	31	64	53	48	45	33	-26
WY	LANDER	1696	33	66	55	50	47	35	-28
WY	JACKSON HOLE (AWOS)	1964	28	61	50	45	42	31	-31
WY	GILLETTE (AMOS)	1230	35	68	57	52	49	38	-27
WY	SHERIDAN	1209	35	68	57	52	49	37	-30
WY	YELLOWSTONE LAKE (RAMOS)	2368	25	58	47	42	39	N/A	N/A
WY	WORLAND MUNICIPAL	1294	36	69	58	53	50	40	-35
WY	CODY MUNI (AWOS)	1553	33	66	55	50	47	35	-28
WY	BIG PINEY (AMOS)	2124	29	62	51	46	43	31	-34

Footnotes:

1. ASHRAE bases its 'warm-season temperature conditions' for each city on annual percentiles of 0.4%, 1.0% and 2.0%. As an example, the June 2.0% dry-bulb design temperature for Atlanta is 91.7F. Therefore, based on a 30-day month (i.e. 720 hours), the actual temperatures can be expected to exceed 91.7F a total of 14 hours a month. The corresponding 1.0% design temperature (93.1F) can be expected to be exceeded for 7 hours a month; while the 0.4% design temperature (94.6F) can be expected to be exceeded for 3 hours a month.
2. Calculations shown in the table are based on ASHRAE 2% design temperatures for 30 years of data*, and CDA research covering three years of monitoring air temperatures inside rooftop conduits.** The table uses the average of the June through August dry-bulb design temperatures—generally the hottest months of the year—in calculating the design temperatures in this table. All temperatures are rounded to the nearest whole number. The results can then be used to apply the correction factors in Table 310.16 of the National Electrical Code.

*ASHRAE has compiled 30 years of dry-bulb design temperature data in the 2005 ASHRAE Handbook of Fundamentals (The American Society of Heating, Refrigerating and Air-Conditioning Engineers. Chapter 28, Climatic Design Information Appendix Section 28.12).

The table covers all of the U.S. weather station locations included in the ASHRAE Handbook. The complete Handbook can be ordered directly from ASHRAE at www.ASHRAE.org.

**The research is described in an article written for the International Association of Electrical Inspectors—IAEI News, Effect of Rooftop Exposure on Ambient Temperatures inside Conduits, January-February, 2006—included elsewhere on this website.